

AccuTemp[®]
INNOVATIVE COOKING EQUIPMENT SOLUTIONS

ACCUSTEAM[™]
HIGH PRODUCTION GRIDDLE

G2 GGF/PGF GAS GRIDDLE PARTS MANUAL



ACCUTEMP PRODUCTS INC
11919 John Adams Dr. New Haven, IN 46774
www.accutemp.net Email: parts@accutemp.net
1-800-480-0415

 **WARNING**

The State of California enacted the California Safe Drinking Water and Toxic Enforcement Act of 1986, (Prop. 65), which “prohibits any person in the course of doing business from knowingly and intentionally exposing any individual to a chemical known to the State of California to cause cancer or reproductive toxicity without first giving clear and reasonable warning to such individuals.”

The Governor’s Scientific Advisory Panel added Carbon Monoxide to the list of hazardous chemicals known to cause reproductive harm.

In order to establish full compliance with Proposition 65, a yellow warning label has been attached to each gas fired unit manufactured by AccuTemp Products, Inc. Carbon monoxide would not be present in concentrations that would pose a “significant risk” to the consumer when the equipment is installed, operated and maintained as follows:

1. Installed in accordance with all local codes, or in the absence of local codes, with the current National Fuel Gas Code Z223.1, latest addenda.
2. Installed under a properly designed and operating exhaust hood.
3. Connected to the type of gas for which the unit is equipped.
4. Proper appliance pressure regulator installed on the gas supply line and adjusted for the manifold pressure marked on the rating plate.
5. Adequate air supply to the unit and adequate clearance around the flue.
6. The equipment is operated in the manner intended using the proper utensil for that type of appliance.
7. Keep the equipment clean and have it checked periodically.
8. Burner air adjustments, mechanical maintenance and repairs should be performed by qualified service personnel.

WARNING SYMBOL DEFINITIONS

SYMBOL DEFINITIONS

Symbols are used to attract your attention to possible dangers. They are only effective if the operator uses proper accident prevention measures. Some of the symbols are boxed text; while others maybe just picture icons. Please give this information the respect they deserve for safe operation.

Symbol Icons

Below are definitions of the symbol icons used in this manual.



DANGER

Indicates an imminently hazardous situation; which, if unchanged, will result in death or serious injury.



CAUTION

Indicates a potentially hazardous situation; which, if unchanged, will result in minor or moderate injury.

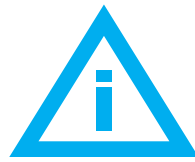

NOTE

Advises the reader of information or instructions, vital to the operation or maintenance of the equipment.



CAUTION - HOT SURFACE



DANGEROUS VOLTAGE

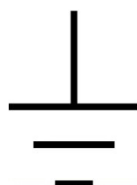

EARTH GROUND

SAFETY PRECAUTIONS



ELECTRICAL SHOCK HAZARD WHILE WORKING ON ENERGIZED EQUIPMENT.

Unplug equipment prior to removing any components effected by electricity.

BURN HAZARD WHILE WORKING ON STEAM PRODUCING EQUIPMENT.

When accessing the cooking chamber, be sure to always stand back while slowly opening the door to allow the chamber to vent off the steam. Never reach into the cooking chamber before it has completely vented off the steam.

Never reach into the cooking chamber or handle hot items without wearing the proper heat protective gloves. Steam coming out of the holes on the right side of the cooking chamber is invisible and can cause severe burns.

Water inside the steam chamber, creating steam, has a temperature of 212°F and will cause burns if touched or spilled on the skin.

PERSONNEL INJURY HAZARD WHILE PICKING UP OR MOVING HEAVY EQUIPMENT.

Always use 2 people and proper lifting techniques when picking-up, moving, or inverting heavy equipment.

SLIP & FALL HAZARD WHILE WORKING ON WATER HOLDING EQUIPMENT.

Keep the floor in front of the equipment clean and dry. If spills occur, clean them up immediately to avoid potential injuries.

Table of Contents

GRIDDLE MODELS GGF & PGF 24" 36" 48"

Fig: 1.1 Control Panel Assembly - Page 6 & 7

Fig: 1.2 Chassis Module, Gas - Page 8, 9 & 10

Fig: 1.3 Rear Gas Lines & Fittings - Page 11

Fig: 1.4 Top Chamber Assy, Gas - Page 12

Fig: 1.5 Frame Assy - Page 13

Fig: 1.6 Gas Control Valve Assy - Page 14

Fig: 1.7 Ceramic Burner 24" S/N: 16514 to 25621 - Page 15

Fig: 1.8 Ceramic Burner 36" S/N: 16514 to 25621 - Page 16

Fig: 1.9 Ceramic Burner 48" S/N: 16514 to 25621 - Page 17

Fig: 2.0 Metal Mesh Burner 24" S/N: 25622 & Up - Page 18

Fig: 2.1 Metal Mesh Burner 36" S/N: 25622 & Up - Page 19

Fig: 2.2 Metal Mesh Burner 48" S/N: 25622 & Up - Page 20

Fig: 2.3 Quick Reference List - Page 21

Fig 1.1 Control Panel Assembly

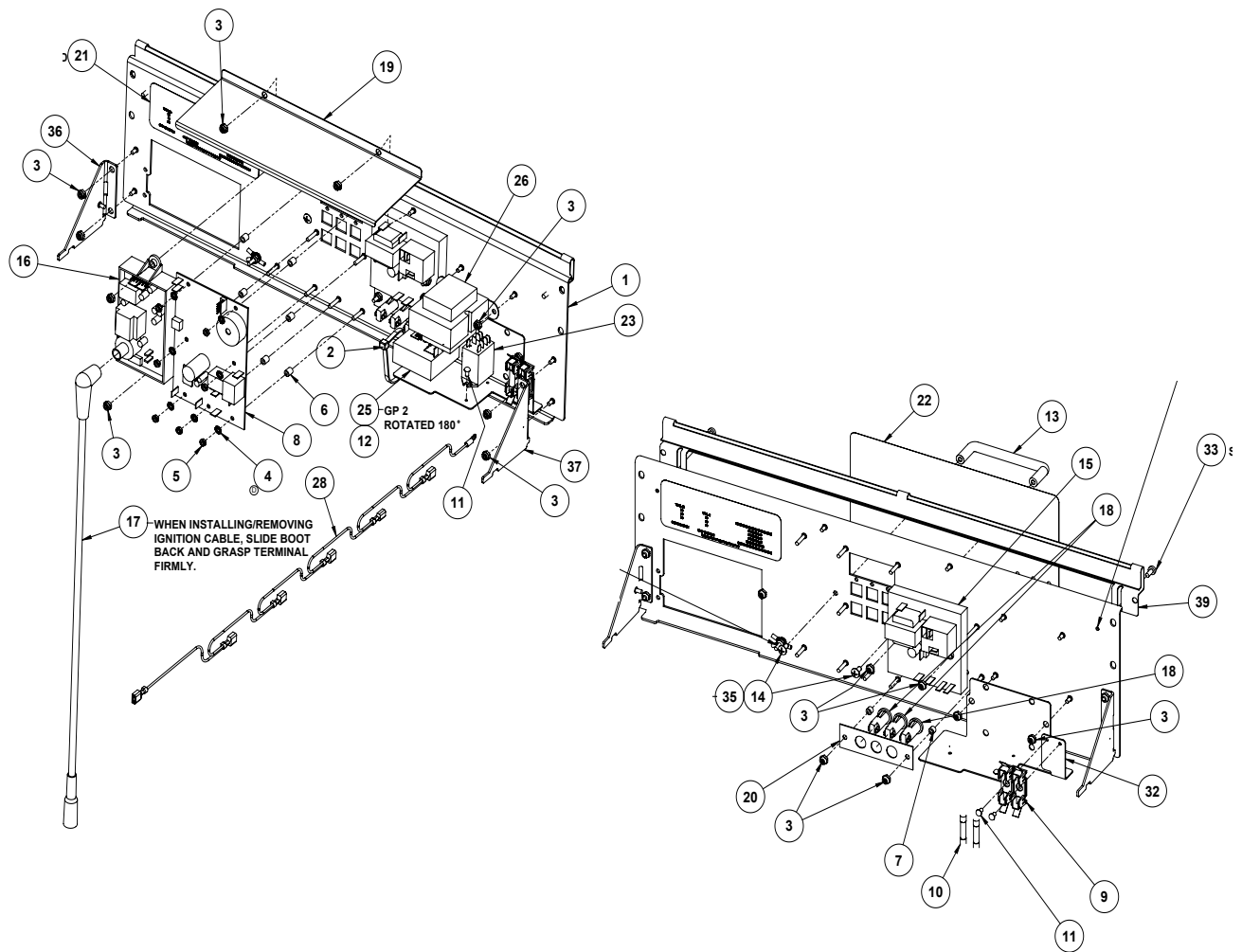

ITEM #	PART NUMBER	DESCRIPTION
#1	AT2A-5021-X	WELD ASSY, CONTROL PANEL
#2	AT0E-2580-1	CABLE TIE
#3	AT0F-2691-21002	NUT, #6-32 NYLOC
#4	AT0F-2666-21000	LOCKWASHER, SS #6 EXTERNAL TOOTH
#5	AT0F-3621-1	NUT, HEX #6-32UNC-2B
#6	AT0H-3623-1	SPACER, ROUND CLEAR HOLE
#7	AT0H-3623-2	SPACER, ROUND CLEAR HOLE
#8	CONTACT ACCUTEMP	CONTROLLER, CIRCUIT BOARD*
#8-1	AT0E-5062-1	PROBE, SENSOR, RTD
#9	AT0E-2708-1	3AG OMNI-BLOK FUSE BLOCK 2 POS
#10	AT0E-2731-2	FUSE 1¼ AMP 250V
#11	AT0F-2755-21020	SCREW, #6-32UNC X 1/4 PHILIPS
#12	AT0F-2755-31080	SCREW, #8-32UNC X 1 PHILIPS
#13	AT0H-4105-5	HANDLE, PULL
#14	AT0F-1046-31030	SCREW, #8-32 x 3/8 PHLP TRUSS HEAD
#15	AT0E-3880-2	HIGH LIMIT CONTROLLER
#15-1	AT0E-5062-1	PROBE, SENSOR, RTD
#16	AT2E-1807-1	IGNITION CONTROLLER
#17	AT2E-1804-4	IGNITION CABLE
#18	AT0E-1800-2	INDICATOR LAMP RED LED 28V
#19	AT2M-4893-1	SHIELD, SPLASH

Fig 1.1 Control Panel Assembly

ITEM #	PART NUMBER	DESCRIPTION
#20	AT1M-3607-1	BRACKET, INDICATOR LAMP
#21	AT2L-2014-2	DATA TAG
#22	AT2L-4557-2	OVERLAY, CONTROL PANEL
#23	AT0E-2825-6	GENERAL PURPOSE RELAY 24VDC
#25	AT0E-2500-3	TIMER RELAY
#26	AT0A-2779-5	TRANSFORMER
#28	AT2A-4454-XX	ASSEMBLY, G2 HARNESS SETS*
#32	AT2M-4801-1	GUARD, TRANSFORMER
#33	AT0F-1046-31030	SCREW, #8-32 x 3/8 PHLP TRUSS HEAD
#33-1	AT0F-3448-31036	SCREW. #8 TAMPER PROOF TRUSS HEAD
#35	AT0H-3065-2	THREAD LOCKER LIQUID 246
#36	AT2A-4962-2	ASSY, HINGE SUPPORT WELD
#37	AT2A-4962-1	ASSY, HINGE SUPPORT WELD
#39	AT2M-5029-1	SHIELD, DEFLECTOR 24" GRIDDLE
#39-1	AT2M-5029-2	SHIELD, DEFLECTOR 36" GRIDDLE
#39-2	AT2M-5029-3	SHIELD, DEFLECTOR 48" GRIDDLE

*CONTACT ACCUTEMP SERVICE PARTS AT 1-800-480-0415 OR EMAIL parts@accutemp.net

Fig 1.2 Chassis Module, Gas

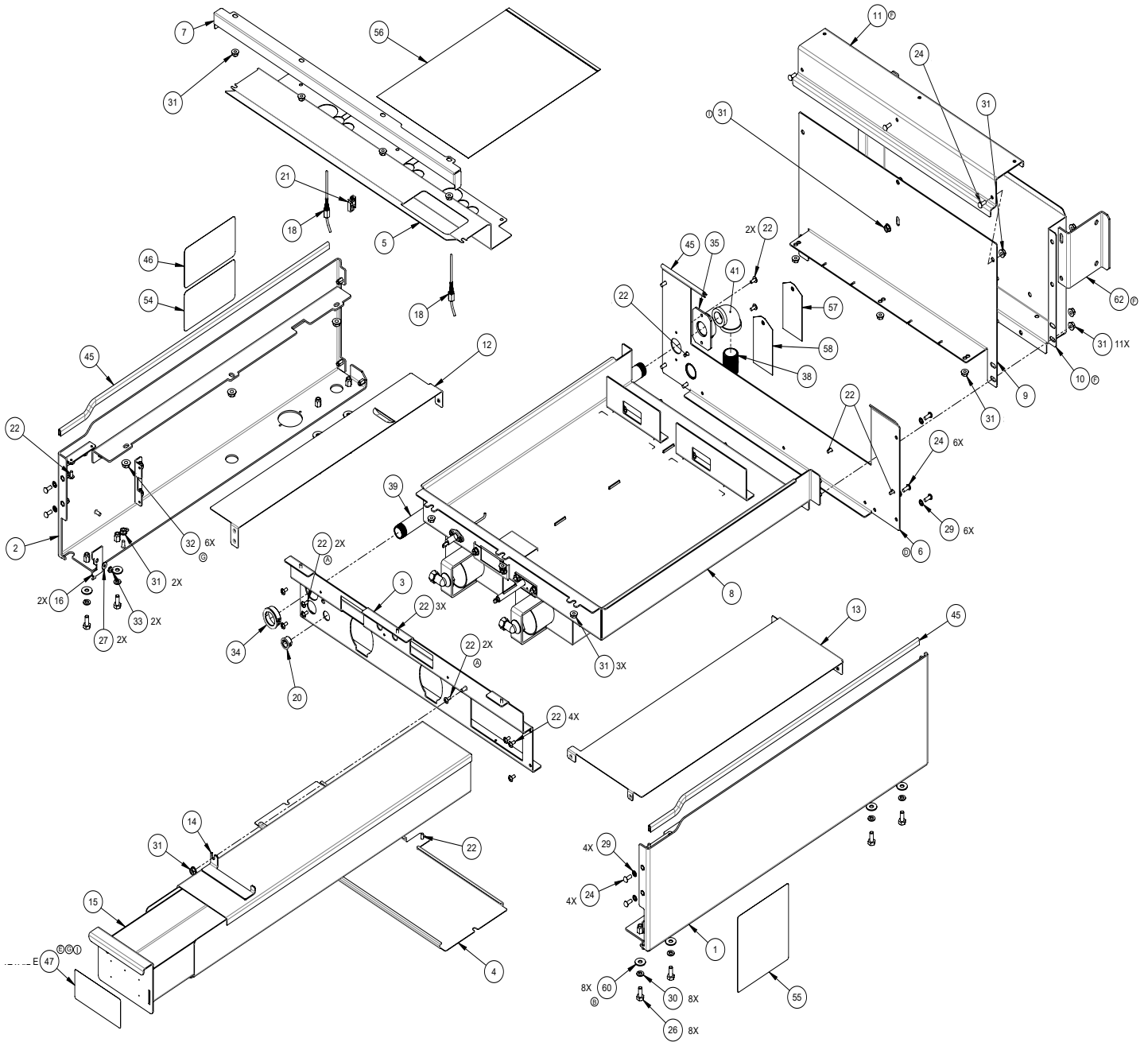

ITEM #	PART NUMBER
#1	AT2A-5004-1
#1-1	AT2A-5004-3
#2	AT2A-5004-2
#2-1	AT2A-5004-4
#3	AT2A-5012-1
#3-1	AT2A-5012-2
#3-2	AT2A-5012-3
#4	AT2M-4897-1
#4-1	AT2M-4897-2
#4-2	AT2M-4897-3
#5	AT2M-5008-1
#5-1	AT2M-5008-2

DESCRIPTION

ASSY, SIDE SUPPORT - RH 24"
ASSY, SIDE SUPPORT - RH 30"
ASSY, SIDE SUPPORT - LH 24"
ASSY, SIDE SUPPORT - LH 30"
REAR SUPPORT ASSEMBLY, CENTER - 24"
REAR SUPPORT ASSEMBLY, CENTER - 36"
REAR SUPPORT ASSEMBLY, CENTER - 48"
PANEL, ENCLOSURE BOTTOM - 24"
PANEL, ENCLOSURE BOTTOM - 36"
PANEL, ENCLOSURE BOTTOM - 48"
SHIELD, HEAT - 24"
SHIELD, HEAT - 36"

Fig 1.2 Chassis Module, Gas

ITEM	#PART NUMBER	DESCRIPTION
#6	AT2M-5187-1	PANEL, REAR - 24" GAS
#6-1	AT2M-5187-2	PANEL, REAR - 36" GAS
#6-2	AT2M-5187-3	PANEL, REAR - 48" GAS
#7	AT2M-5018-1	SHIELD, GREASE - 24"
#7-1	AT2M-5018-2	SHIELD, GREASE - 36"
#7-2	AT2M-5018-3	SHIELD, GREASE - 48"
#8	AT2A-4950-4	ASSY, COMBUSTION CHAMBER - 24" X 30"
#8-1	AT2A-4950-1	ASSY, COMBUSTION CHAMBER - 24" X 24"
#8-2	AT2A-4950-5	ASSY, COMBUSTION CHAMBER - 36" X 30"
#8-3	AT2A-4950-2	ASSY, COMBUSTION CHAMBER - 36" X 24"
#8-4	AT2A-4950-6	ASSY, COMBUSTION CHAMBER - 48" X 30"
#8-5	AT2A-4950-3	ASSY, COMBUSTION CHAMBER - 48" X 24"
#9	AT2A-4954-1	INNER FLUE PANEL ASSY 24"
#9-1	AT2A-4954-2	INNER FLUE PANEL ASSY 36"
#9-2	AT2A-4954-3	INNER FLUE PANEL ASSY 48"
#10	AT2M-5716-1	OUTER FLUE 24"
#10-1	AT2M-5716-2	OUTER FLUE 36"
#10-2	AT2M-5716-3	OUTER FLUE 48"
#11	AT2M-5714-1	BRACKET, DRAFT DIVERter - 24"
#11-1	AT2M-5714-2	BRACKET, DRAFT DIVERter - 36"
#11-2	AT2M-5714-3	BRACKET, DRAFT DIVERter - 48"
#12	AT2M-5014-7	COVER, INSULATION, GAS - LH 24 X 30
#12-1	AT2M-5014-1	COVER, INSULATION, GAS - LH 24 X 24
#12-2	AT2M-5014-8	COVER, INSULATION, GAS - LH 36 X 30
#12-3	AT2M-5014-2	COVER, INSULATION, GAS - LH 36 X 24
#12-4	AT2M-5014-9	COVER, INSULATION, GAS - LH 48 X 30
#12-5	AT2M-5014-3	COVER, INSULATION, GAS - LH 48 X 24
#13	AT2M-5014-10	COVER, INSULATION, GAS - RH 24 X 30
#13-1	AT2M-5014-4	COVER, INSULATION, GAS - RH 24 X 24
#13-2	AT2M-5014-12	COVER, INSULATION, GAS - RH (36 & 48) X 30
#13-3	AT2M-5014-6	COVER, INSULATION, GAS - RH (36 & 48) X 24
#14	AT2A-4885-1	GREASE CAN ASSY - 24" FRONT GR TR
#14-1	AT2A-4885-2	GREASE CAN ASSY - 36 & 48" FR GR TR
#15	AT2A-4937-9	ASSY, GREASE TRAY - 24"
#15-1	AT2A-4937-10	ASSY, GREASE TRAY - 36" & 48"
#16	AT2M-4787-1	LOCK, HINGE
#18	ATOE-5062-1	PROBE, SENSOR, RTD
#20	ATOH-2576-4	GROMMET, 5/8" NYLON
#21	ATOE-4618-1	WIRE SADDLE, LOCKING
#22	ATOF-1046-31030	SCREW, #8-32 x 3/8 PHLP TRUSS HEAD
#24	ATOF-2755-41040	SCREW, #10-24UNC X 1/2 PHILIPS ROUND HEAD
#26	ATOF-2875-51050	SCREW, 1/4-20UNC X 5/8 HEX HEAD
#27	ATOF-1052-21002	WASHER #6 TYPE B PLAIN
#29	ATOF-2666-40000	WASHER, SS #10 INTERNAL TOOTH LOCK
#30	ATOF-1922-50000	WASHER, 1/4" HELICAL SPRING LOCK
#31	ATOF-1017-41002	NUT, #10-24UNC HEX SERRATED
#32	ATOF-1017-51002	NUT, 1/4-20UNC HEX SERRATED

Fig 1.2 Chassis Module, Gas

ITEM #	PART NUMBER	DESCRIPTION
#33	AT0F-2691-21002	NUT, #6-32 NYLOC
#3	AT0H-2576-2	GROMMET, 1¼" NYLON
#35	AT1A-3878-1	SHAFT COLLAR WELDMENT
#36	AT0P-2090-1	TEE 1/2 NPT SCH 40
#38	AT2P-2465-1	PIPE, 3/4" NPT CLOSE NIPPLE
#39	AT0P-3567-32300	1/2" NPT x 30" LONG BLACK IRON PIPE
#39-1	AT0P-3567-32240	1/2" NPT x 24" LONG BLACK IRON PIPE
#41	AT2P-2466-1	ELBOW, REDUCING
#45	AT0G-5033-1	SEAL, GASKET, BULB
#46	AT0L-4933-1	LABEL, WARNING, PROPOSITION 65
#47	AT0L-6466-1	OVERLAY, GREASE TRAY
#54	AT0L-2802-1	OVERLAY, NOTICE, MOBILE APPLIANCE
#55	AT0L-2799-1	OVERLAY, WARNING, GAS FIRED GRIDDLE
#56	AT2A-4987-1	LOOSE PIECES, GRIDDLE
#57	AT0L-2936-2	TAG GAS REGULATOR
#58	AT0L-2936-1	TAG POWER CORD
#60	AT0F-1052-51000	WASHER 1/4 TYPE B PLAIN STAINLESS STEEL
#62	AT2M-3450-1	BRACKET, BACK STOP

Fig 1.3 Front Gas Lines & Fittings

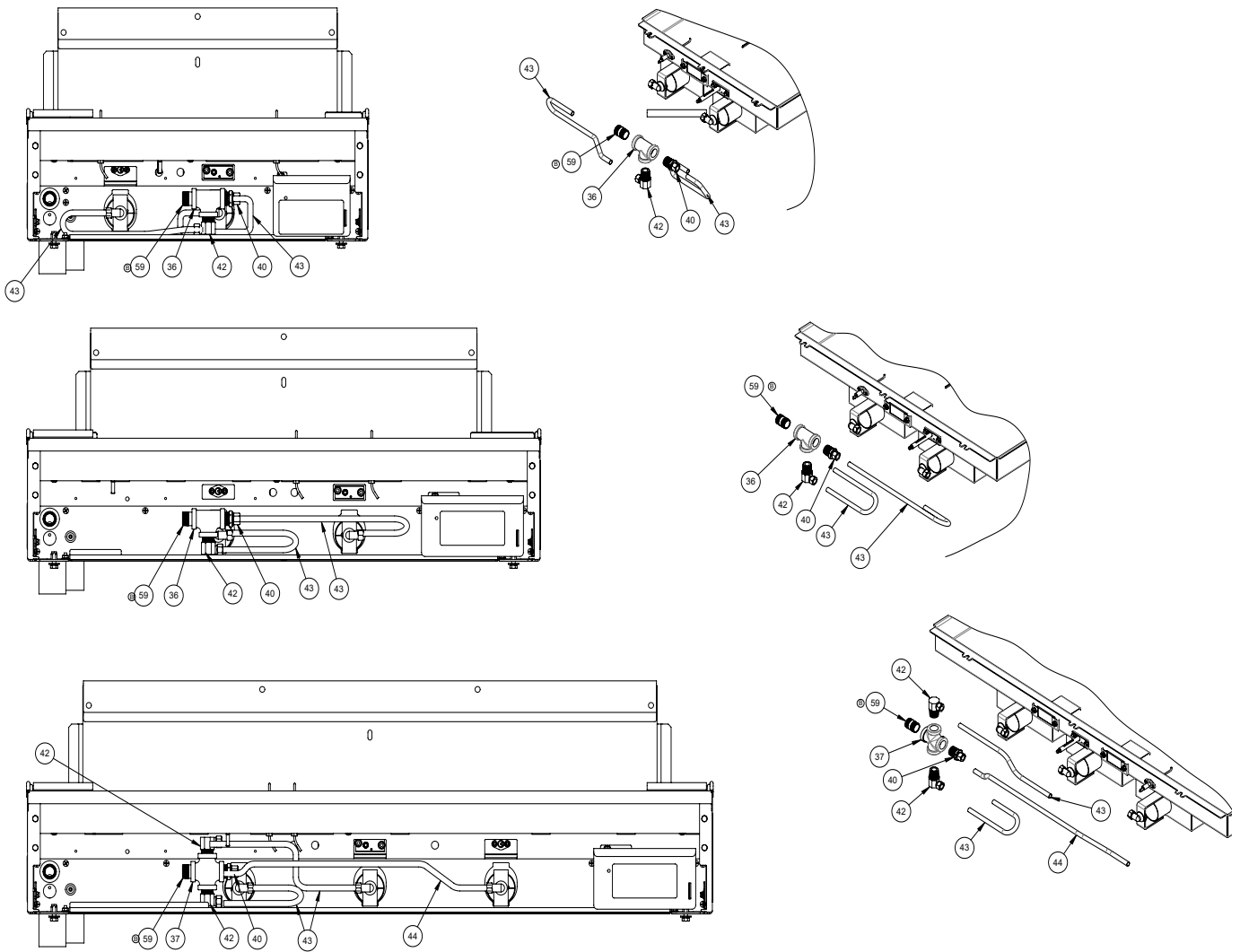

ITEM #	PART NUMBER	DESCRIPTION
#36	ATOP-2090-1	TEE 1/2 NPT SCH 40
#37	ATOP-2844-1	CROSS, 1/2 NPT SCH 40
#40	ATOP-2097-2	COMPRESSION FITTING TO MALE PIPE
#42	ATOP-2096-1	ELBOW 90° 1/2 NPT TO 3/8 TUBE
#43	AT2P-2104-1	3/8" FLEX TUBING 13.00" LG
#44	AT2P-2105	19" LONG 3/8 FLEXTUBE COMP ENDS
#59	ATOP-3567-32000	NIPPLE, CLOSE, BLACK IRON-1/2" NPT

Fig 1.4 Top Chamber Assy, Gas

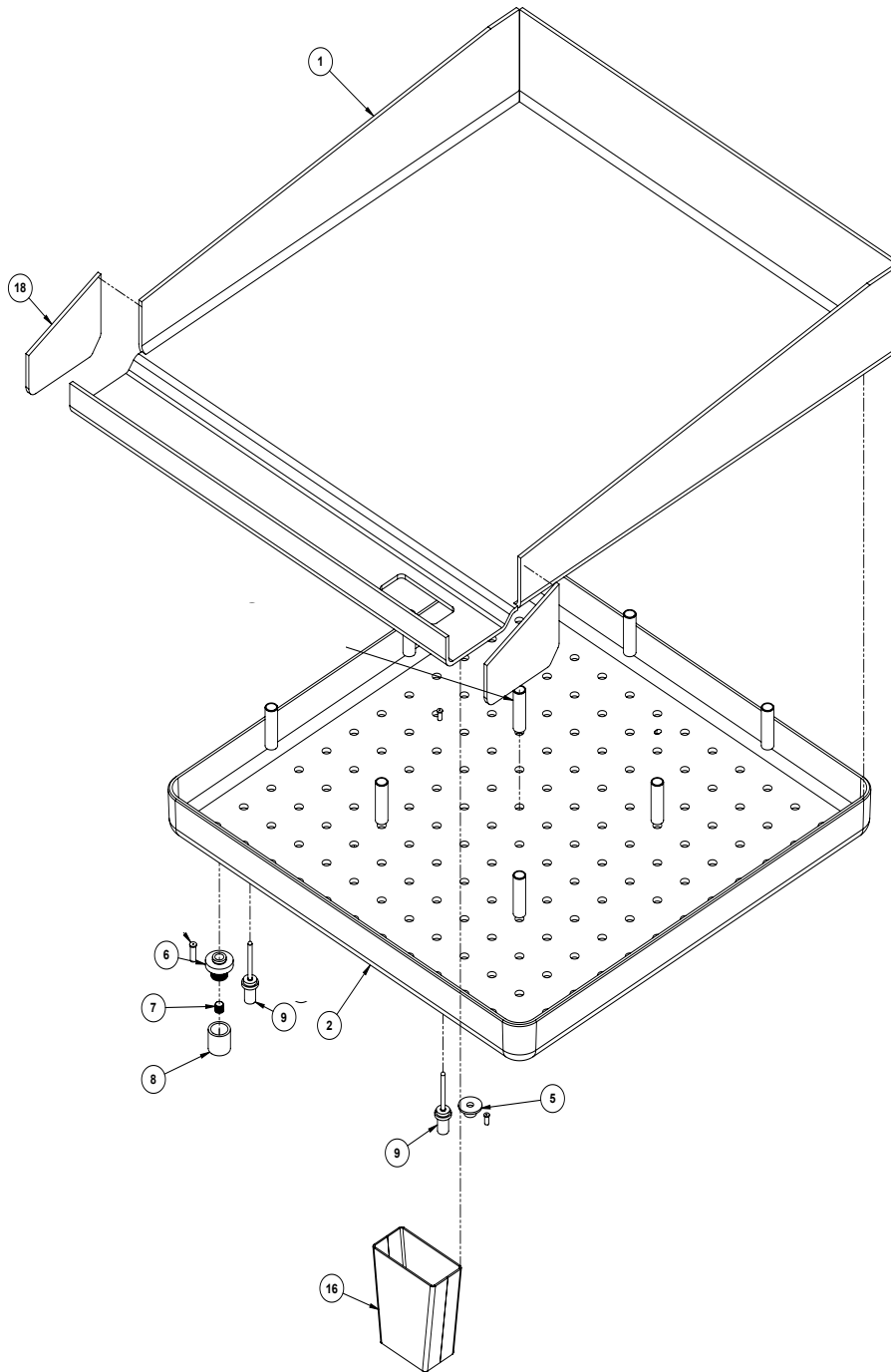

ITEM #	PART NUMBER	DESCRIPTION
#1	AT2A-3563-X	CHAMBER TOP WELD ASSY*
#2	AT2M-3021-X	CHAMBER BOTTOM GAS GRIDDLE*
#5	AT2M-2122-X	RUPTURE DISC*
#6	AT2P-1152-1	COUPLER, STEPPED, 1/8 NPT
#7	AT0P-3024-3	PLUG COUNTERSUNK HEX HEAD
#8	AT2P-1445-1	CAP
#9	AT0E-2884-X	THERMOWELL, NOT REPLACEABLE*
#16	AT2A-4945-1	EXTENSION ASSEMBLY, GREASE SPOUT, TAPERED
#18	AT2M-5007-1	FRONT END CAP

*CONTACT ACCUTEMP SERVICE PARTS AT 1-800-480-0415 OR EMAIL parts@accutemp.net

Fig 1.5 Frame Assy

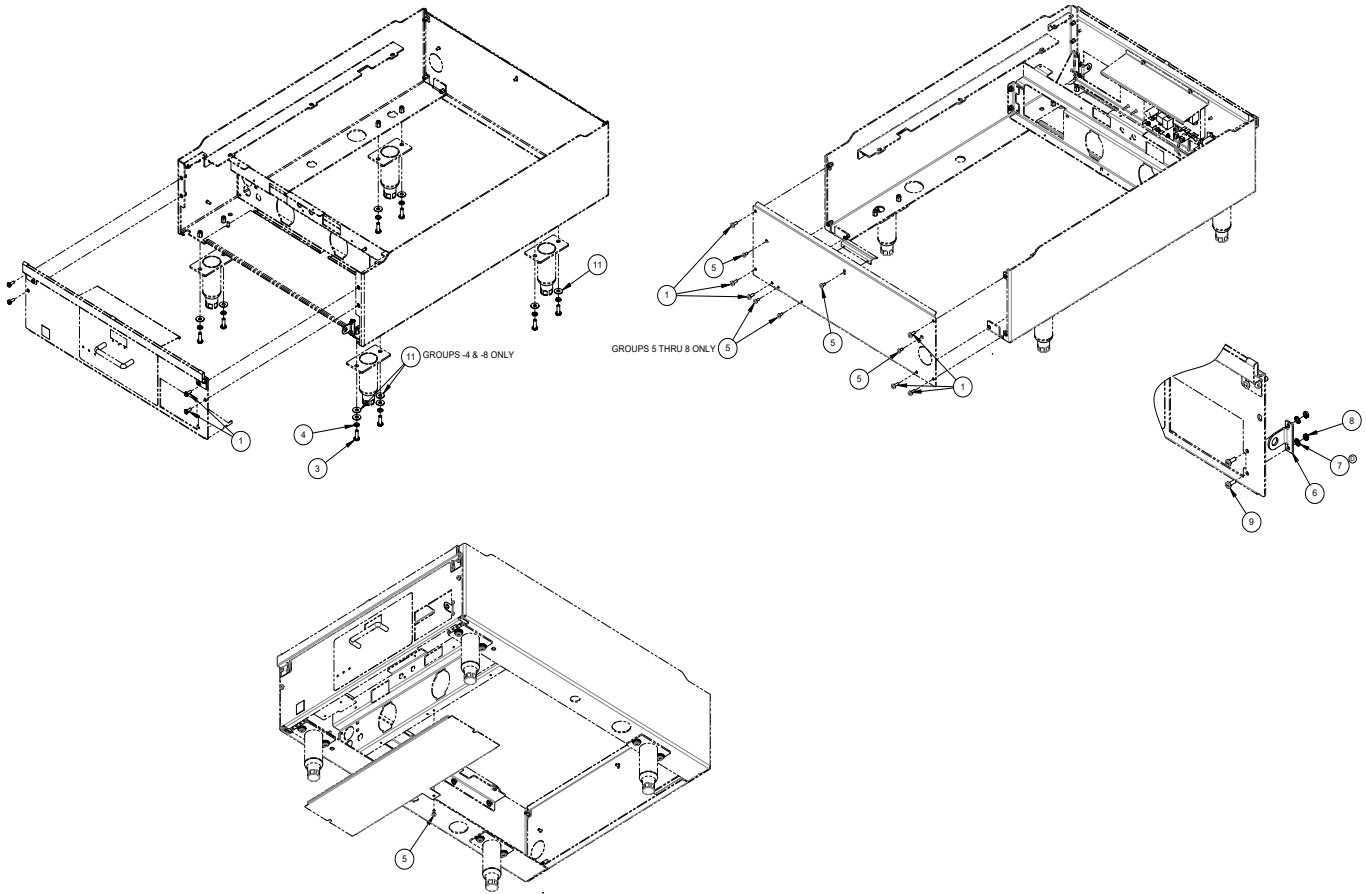

ITEM #	PART NUMBER	DESCRIPTION
#1	ATOF-2755-41040	SCREW, #10-24UNC X 1/2 PHILIPS
#1-1	ATOF-3448-41046	SCREW, #10-24 X 1/2" DRL SPAN PAN HD
#3	ATOF-2875-51050	SCREW, 1/4-20UNC X 5/8 HEX HEAD
#3-1	ATOF-3448-51066	SCREW, 1/4-20 X 3/4" DRL SPAN PAN HD
#4	ATOF-1922-50000	WASHER, 1/4" HELICAL SPRING LOCK
#5	ATOF-1046-31030	SCREW, #8-32 x 3/8 PHLP TRUSS HEAD
#5-1	ATOF-3448-31036	SCREW, #8-32 X 3/8" DRL SPAN PAN HD
#6	AT2M-4736-1	EYE, PADLOCK
#7	ATOF-2666-21000	WASHER, SS #6 EXTERNAL TOOTH LOCK
#8	ATOF-3621-1	NUT, #6-32 UNC-2B HEX
#9	ATOF-3448-21030	SCREW, #6-32 X 3/8" DRL SPAN PAN HD
#11	ATOF-1052-51000	WASHER 1/4 TYPE B PLAIN STAINLESS STEEL
#12	ATOF-2061-41060	SCREW, #10-24 x 3/4" FLAT HD MACHINE

Fig 1.6 Gas Control Valve Assy

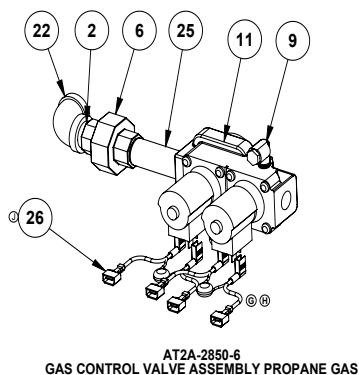
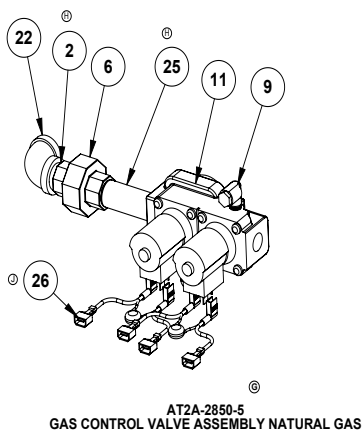

ITEM #	PART NUMBER	DESCRIPTION
#2	ATOP-3567-32000	NIPPLE, CLOSE, BLACK IRON-1/2" NPT
#6	ATOP-2843-1	UNION BLACK IRON
#9	ATOP-2849-3	STREET ELBOW 90°
#11	AT2E-1806-2	CONTROL VALVE, GAS 5" W.C. NATURAL GAS
#11-1	AT2E-1806-3	CONTROL VALVE, GAS 10" W.C. PROPANE GAS
#22	ATOP-2972-1	ELBOW, 1/2 NPT SCH 40 90°
#25	ATOP-3567-32030	NIPPLE, CLOSE, BLACK IRON-1/2" NPT 3" LONG
#26	AT0A-2736-12	MOV- TERMINALS ASSEMBLY 30V

*CONTACT ACCUTEMP SERVICE PARTS AT 1-800-480-0415 OR EMAIL parts@accutemp.net

Fig 1.7 Ceramic Burner 24" S/N: 16514 to 25621

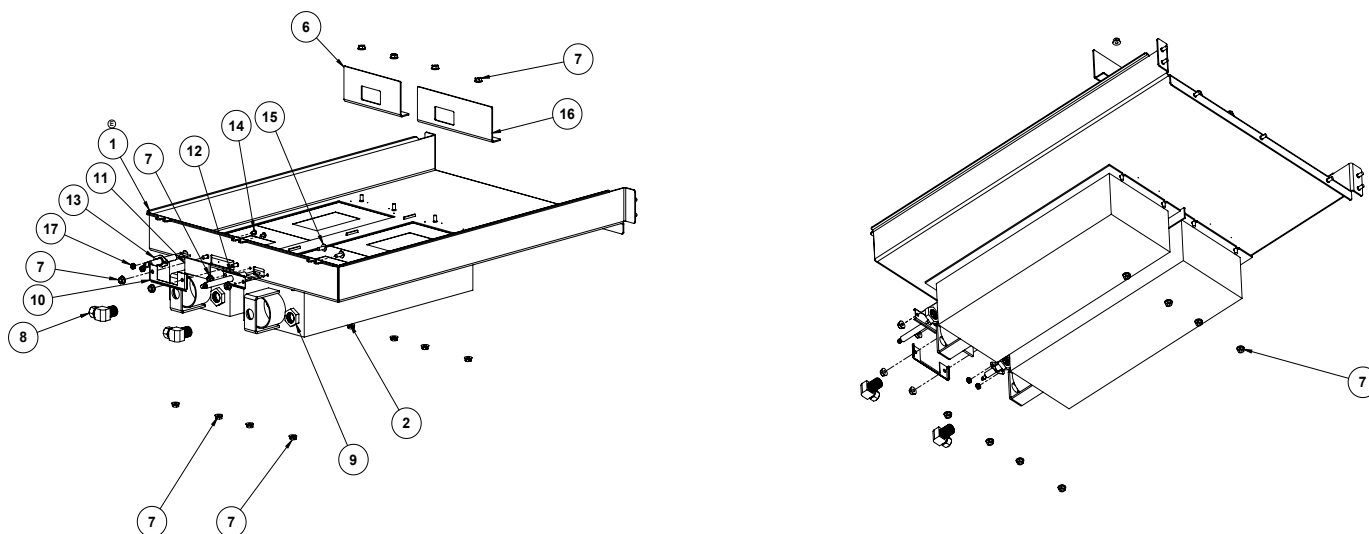

ITEM #	PART NUMBER	DESCRIPTION
#1	AT2A-5818-XX	ASSEMBLY, COMBUSTION CHAMBER WELD*
#2	AT2B-2131-2	20,000 BTU IR MAIN CERAMIC BURNER
#6	AT2M-3562-1	BARRIER, FLUE GAS
#7	AT0F-1017-41002	NUT, #10-24UNC HEX SERRATED
#8	AT0B-2891-1	ELBOW 90° COMPRESSION
#9	AT0F-2909-1	NPT PIPE LOCKNUT
#10	AT2M-3638-1	BRACKET, SIGHT GLASS
#11	AT2H-3637-1	GLASS, SIGHT
#12	AT2E-4716-1	IGNITOR
#13	AT2E-4717-1	SENSOR, FLAME
#14	AT0F-1046-21032	SCREW, #6-32 x 1/4 PHLP TRUSS HEAD
#15	AT0F-1046-41042	SCREW, #10-24 x 3/8 PHLP TRUSS HEAD
#16	AT2M-3562-5	BARRIER, FLUE GAS
#17	AT0F-4616-21002	NUT, KEPS

*CONTACT ACCUTEMP SERVICE PARTS AT 1-800-480-0415 OR EMAIL parts@accutemp.net

Fig 1.8 Ceramic Burner 36" S/N: 16514 to 25621

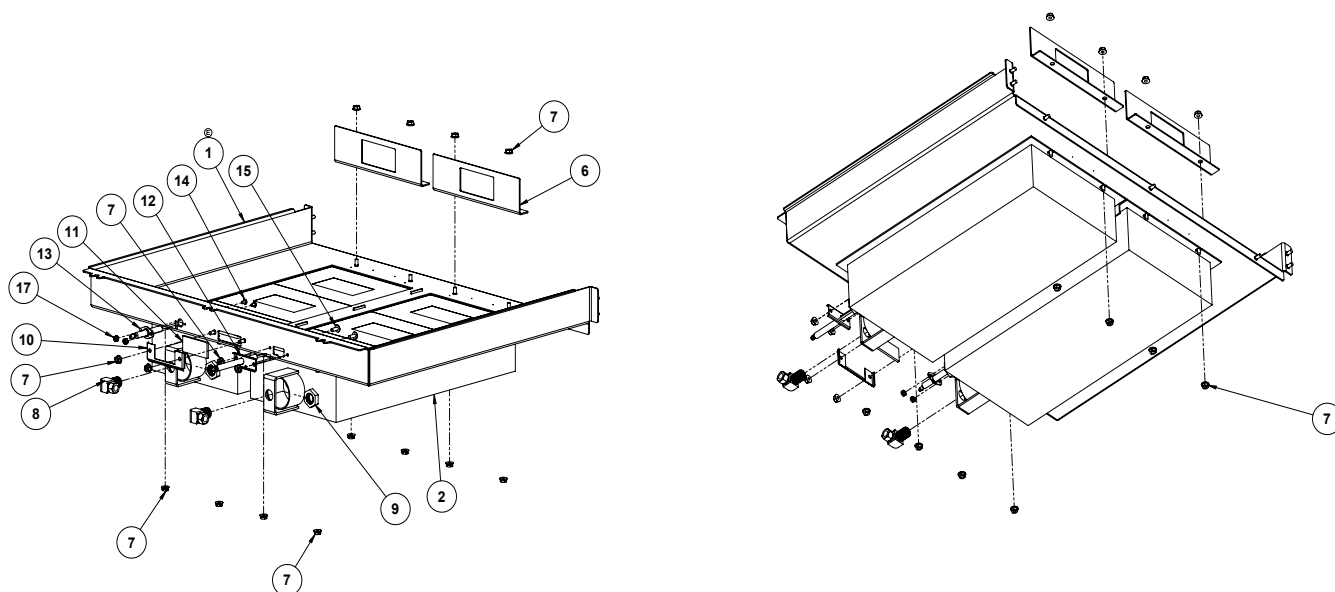

ITEM #	PART NUMBER	DESCRIPTION
#1	AT2A-5818-XX	ASSEMBLY, COMBUSTION CHAMBER WELD*
#2	AT2B-2099-2	30,000 BTU IR MAIN CERAMIC BURNER
#6	AT2M-3562-2	BARRIER, FLUE GAS
#7	AT0F-1017-41002	NUT, #10-24UNC HEX SERRATED
#8	AT0B-2891-1	ELBOW 90° COMPRESSION
#9	AT0F-2909-1	NPT PIPE LOCKNUT
#10	AT2M-3638-1	BRACKET, SIGHT GLASS
#11	AT2H-3637-1	GLASS, SIGHT
#12	AT2E-4716-1	IGNITOR
#13	AT2E-4717-1	SENSOR, FLAME
#14	AT0F-1046-21032	SCREW, #6-32 x 1/4 PHLP TRUSS HEAD
#15	AT0F-1046-41042	SCREW, #10-24 x 3/8 PHLP TRUSS HEAD
#16	AT2M-3562-5	BARRIER, FLUE GAS
#17	AT0F-4616-21002	NUT, KEPS

*CONTACT ACCUTEMP SERVICE PARTS AT 1-800-480-0415 OR EMAIL parts@accutemp.net

Fig 1.9 Ceramic Burner 48" S/N: 16514 to 25621

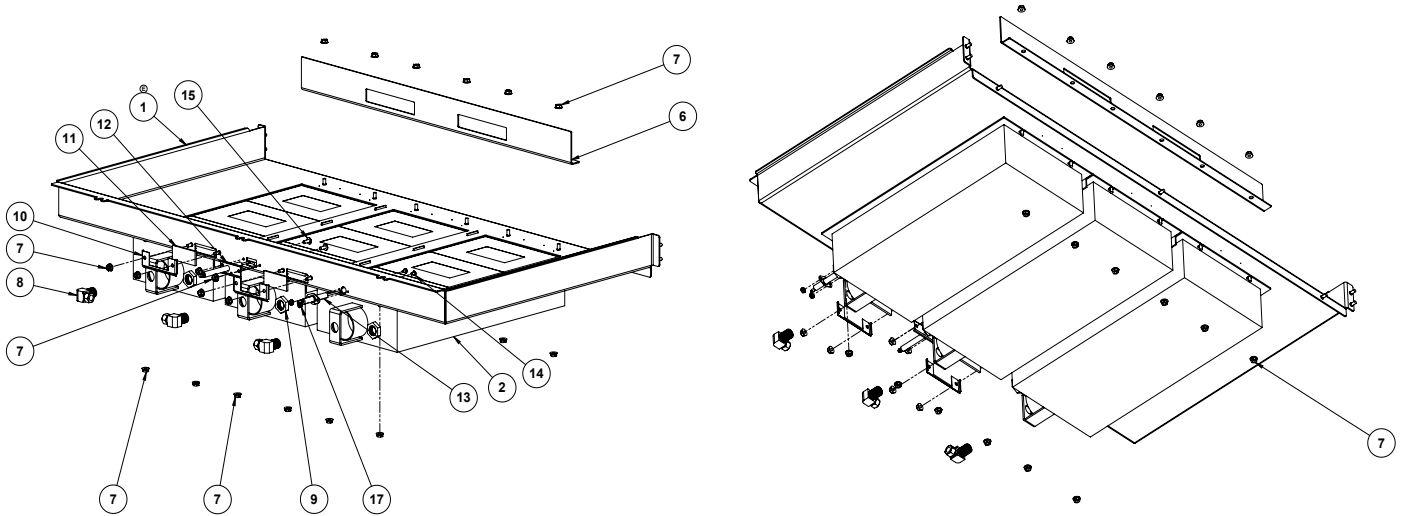

ITEM #	PART NUMBER	DESCRIPTION
#1	AT2A-5818-XX	ASSEMBLY, COMBUSTION CHAMBER WELD*
#2	AT2B-2099-2	30,000 BTU IR MAIN CERAMIC BURNER
#6	AT2M-3562-3	BARRIER, FLUE GAS
#7	AT0F-1017-41002	NUT, #10-24UNC HEX SERRATED
#8	AT0B-2891-1	ELBOW 90° COMPRESSION
#9	AT0F-2909-1	NPT PIPE LOCKNUT
#10	AT2M-3638-1	BRACKET, SIGHT GLASS
#11	AT2H-3637-1	GLASS, SIGHT
#12	AT2E-4716-1	IGNITOR
#13	AT2E-4717-1	SENSOR, FLAME
#14	AT0F-1046-21032	SCREW, #6-32 x 1/4 PHLP TRUSS HEAD
#15	AT0F-1046-41042	SCREW, #10-24 x 3/8 PHLP TRUSS HEAD
#16	AT2M-3562-5	BARRIER, FLUE GAS
#17	AT0F-4616-21002	NUT, KEPS

*CONTACT ACCUTEMP SERVICE PARTS AT 1-800-480-0415 OR EMAIL parts@accutemp.net

Fig 2.0 Metal Mesh Burner 24" S/N: 25622 & UP

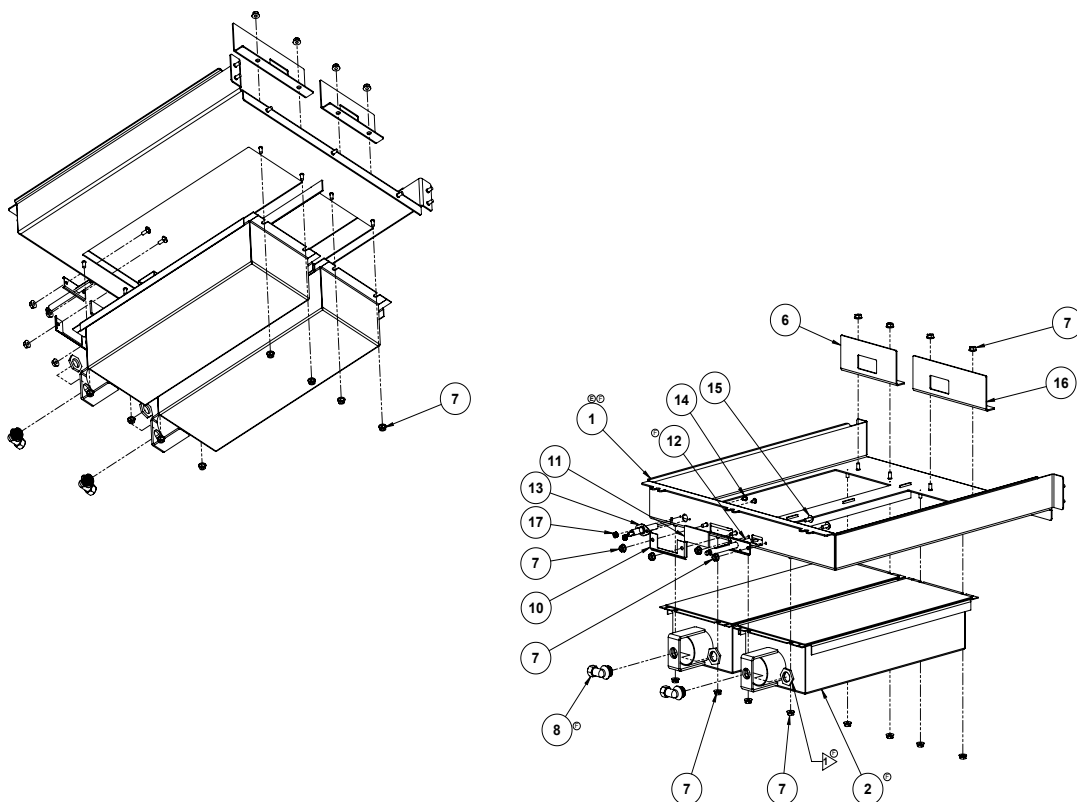

ITEM #	PART NUMBER	DESCRIPTION
#1	AT2A-6569-XX	ASSEMBLY, COMBUSTION CHAMBER WELD*
#2	AT2B-6446-1	METAL MESH BURNER, 24" 20,000 BTU
#6	AT2M-3562-1	BARRIER, FLUE GAS
#7	AT0F-1017-41002	NUT, #10-24UNC HEX SERRATED
#8	AT0B-2891-1	ELBOW 90° COMPRESSION
#9	AT0F-2909-1	NPT PIPE LOCKNUT
#10	AT2M-3638-1	BRACKET, SIGHT GLASS
#11	AT2H-3637-1	GLASS, SIGHT
#12	AT2E-6448-1	IGNITOR
#13	AT2E-4717-1	SENSOR, FLAME
#14	AT0F-1046-21032	SCREW, #6-32 x 1/4 PHLP TRUSS HEAD
#15	AT0F-1046-41042	SCREW, #10-24 x 3/8 PHLP TRUSS HEAD
#16	AT2M-3562-5	BARRIER, FLUE GAS
#17	AT0F-4616-21002	NUT, KEPS

*CONTACT ACCUTEMP SERVICE PARTS AT 1-800-480-0415 OR EMAIL parts@accutemp.net

Note: When converting from Ceramic Burners to Metal Mesh Burners order Part Number AT2Z-6450 Metal Mesh Burner Kit 24"

Fig 2.1 Metal Mesh Burner 36" S/N: 25622 & UP

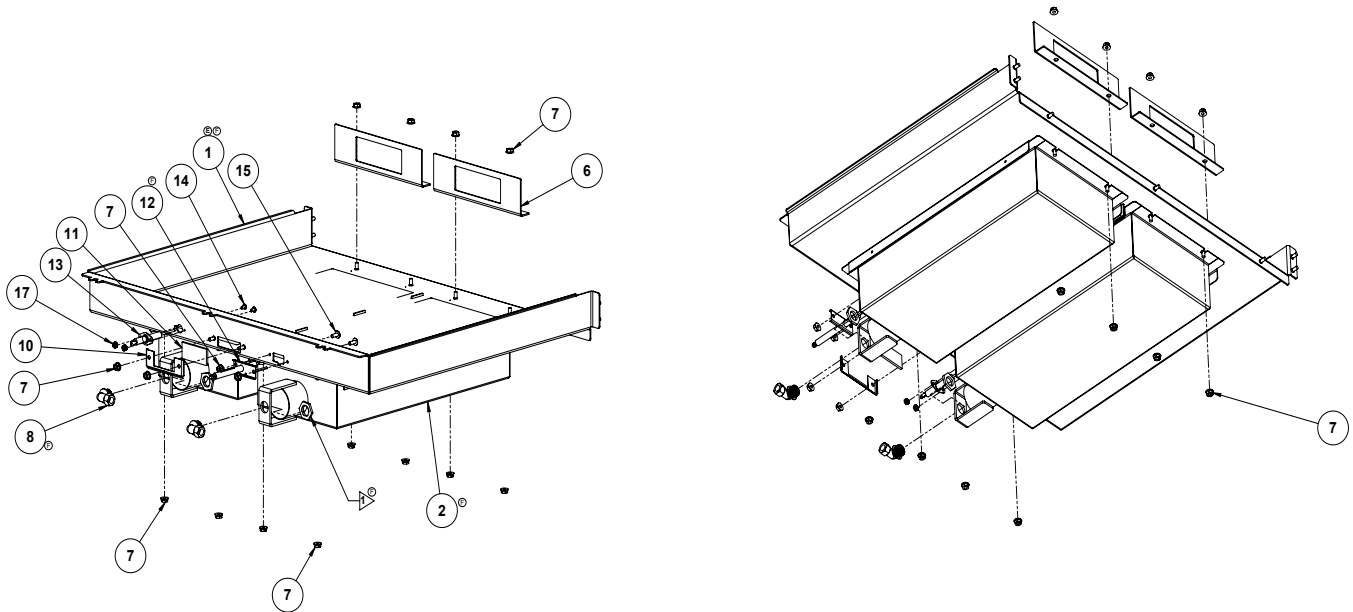

ITEM #	PART NUMBER	DESCRIPTION
#1	AT2A-6569-XX	ASSEMBLY, COMBUSTION CHAMBER WELD*
#2	AT2B-6445-1	METAL MESH BURNER, 36" 30,000 BTU
#6	AT2M-3562-2	BARRIER, FLUE GAS
#7	AT0F-1017-41002	NUT, #10-24UNC HEX SERRATED
#8	AT0B-2891-1	ELBOW 90° COMPRESSION
#9	AT0F-2909-1	NPT PIPE LOCKNUT
#10	AT2M-3638-1	BRACKET, SIGHT GLASS
#11	AT2H-3637-1	GLASS, SIGHT
#12	AT2E-6448-1	IGNITOR
#13	AT2E-4717-1	SENSOR, FLAME
#14	AT0F-1046-21032	SCREW, #6-32 x 1/4 PHLP TRUSS HEAD
#15	AT0F-1046-41042	SCREW, #10-24 x 3/8 PHLP TRUSS HEAD
#16	AT2M-3562-5	BARRIER, FLUE GAS
#17	AT0F-4616-21002	NUT, KEPS

*CONTACT ACCUTEMP SERVICE PARTS AT 1-800-480-0415 OR EMAIL parts@accutemp.net

Note: When converting from Ceramic Burners to Metal Mesh Burners order Part Number AT2Z-6451 Metal Mesh Burner Kit 36"

Fig 2.2 Metal Mesh Burner 48" S/N: 25622 & UP

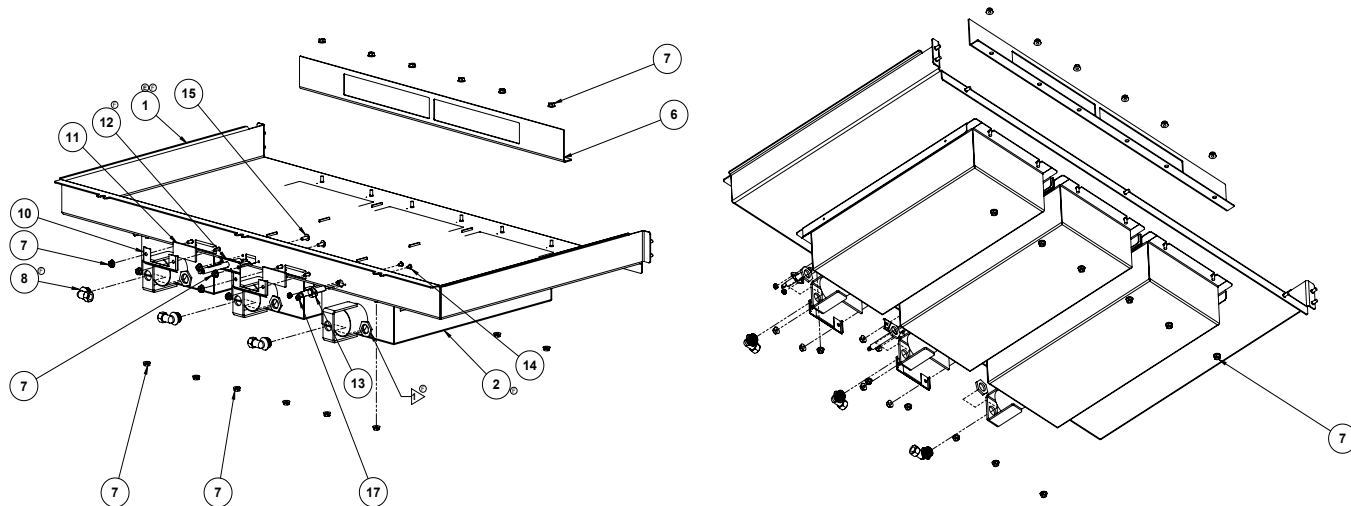

ITEM #	PART NUMBER	DESCRIPTION
#1	AT2A-6569-XX	ASSEMBLY, COMBUSTION CHAMBER WELD*
#2	AT2B-6445-1	METAL MESH BURNER, 48" 30,000 BTU
#6	AT2M-3562-3	BARRIER, FLUE GAS
#7	AT0F-1017-41002	NUT, #10-24UNC HEX SERRATED
#8	AT0B-2891-1	ELBOW 90° COMPRESSION
#9	AT0F-2909-1	NPT PIPE LOCKNUT
#10	AT2M-3638-1	BRACKET, SIGHT GLASS
#11	AT2H-3637-1	GLASS, SIGHT
#12	AT2E-6448-1	IGNITOR
#13	AT2E-4717-1	SENSOR, FLAME
#14	AT0F-1046-21032	SCREW, #6-32 x 1/4 PHLP TRUSS HEAD
#15	AT0F-1046-41042	SCREW, #10-24 x 3/8 PHLP TRUSS HEAD
#16	AT2M-3562-5	BARRIER, FLUE GAS
#17	AT0F-4616-21002	NUT, KEPS

*CONTACT ACCUTEMP SERVICE PARTS AT 1-800-480-0415 OR EMAIL parts@accutemp.net

Note: When converting from Ceramic Burners to Metal Mesh Burners order Part Number AT2Z-6452 Metal Mesh Burner Kit 48"

Fig 2.3 Quick Reference List

Part Number	Description
CONTACT ACCUTEMP	Main Controller, Circuit Board
AT0E-5062-1	RTD Probe Sensor
AT0E-3880-2	Hi-Limit Control Circuit Board
AT2E-1807-1	Ignition Control Module
AT2A-4454-51	Ignition Control Harness
AT2E-1806-2	Control Valve Natural Gas
AT2E-1806-3	Control Valve Propane Gas
AT0A-2779-5	Transformer 24V
AT0E-2500-3	Timer
AT0E-2731-2	Fuse 1 Amp 250V
AT0E-2825-6	Relay
AT0A-2911-1	Power Cord Assembly, 120v - GAS
AT0F-1017-41002	Burner Nut
AT0F-1046-31030	Front Panel Screw; All Models
AT0H-4982-1	24" Natural Gas to Propane Gas Kit
AT0H-4982-2	36" Natural Gas to Propane Gas Kit
AT0H-4982-3	48" Natural Gas to Propane Gas Kit
AT0H-4982-4	24" Propane Gas to Natural Gas Kit
AT0H-4982-5	36" Propane Gas to Natural Gas Kit
AT0H-4982-6	48" Propane Gas to Natural Gas Kit
AT2A-5043-1	24" Grab Handle / Towel Bar Kit
AT2A-5043-2	36" Grab Handle / Towel Bar Kit
AT2A-5043-3	48" Grab Handle / Towel Bar Kit
AT2M-4797-1	RH Condiment Bracket
AT2M-4797-2	LH Condiment Bracket



LIFETIMETM
SERVICE & SUPPORT
1-800-480-0415 | service@accutemp.net