

Project: _____ Location: _____ Item #: _____ Quantity: _____

Standard Features

- Fast cook, low temp, steam and hold modes
- Super Duty heater configuration
- No water or drain line required
- No hood required (in most areas)
- 3 gallon water reservoir
- Heating element not exposed to water
- No deliming, descaling, or blowdowns
- No water quality exclusions to warranty
- Heavy duty door
- Low water protection with light and buzzer
- Heat, cook, and hold indicator lights
- Fast cook and thermostat mode selector switch
- Vacuum and temperature gauges
- Certified as a holding cabinet
- 90 minute timer
- Right hand hinged door
- Quick release door—open door while cooking
- Patented vacuum technology for efficiency & faster cooking
- Continuous cook and hold mode settings on timer
- Power on/off switch
- Steamer cavity made of durable reinforced 14 ga. 304 stainless steel
- (2) 5' power cords and plugs included, separate receptacle needed for each unit
- Front mounted drain valve
- Exclusive and patented low temperature steam cooking mode
- Multiple kilowatt outputs available to suit cooking needs
- One year parts and labor warranty
- Lifetime Service and Support Guarantee
- Steam Director covers water for added safety
- Field Reversible Door

Optional Features

- Chain package—factory preset hold temperature; controls behind panel
- Military package
- Corrections package—tamper resistant
- Marine package
- Drain kit
- Stainless steel support stand available with casters, bullet or flanged feet
- Double stacking stand conversion kit
- Perforated cooking shelf
- Steamer door crack open/hold open feature
- 4" full size (12x20x4") drain pan
- One year extended warranty

Safety, Sanitation & Environmental



- EPA 202 Evaluated / NFPA 96 4.1.1.2 Compliant



Pan Capacities

Pan Size	Qty.
#200 full size (12x20x2.5")	9
#400 full size (12x20x4")	6

Short Spec

Steam&Hold™ steamer is AccuTemp Products patented vacuum technology steam cooker with 3 operating modes. Fast cook (212°F), low temperature steam mode (150–200°F) and NSF certified variable temperature hold mode. Steam to be produced inside the cooking cavity with no heating element exposed to water. No water or drain line required. Unit to include heavy duty door which will open at any time during cooking cycle. Steamer to include low water indicator light and buzzer with auto shutdown feature. Unit to be UL, CE, and ENERGY STAR® qualified. Built in the USA. Steamers to be mounted on a stainless steel stand.



S3/S6 Double Stacked Steam&Hold™ shown with double stack stand (with casters) and 4" drain pans

Steamer Model "D" Specifications per cavity DBL = TWO CAVITIES						
Model #	S3/S62081D060 DBL	S3/S62401D060 DBL	S3/S62083D100 DBL	S3/S62403D110 DBL	S3/S62083D120 DBL	S3/S62403D130 DBL
Volts AC	208	240	208	240	208	240
Phase	1	1	3	3	3	3
Amps	29	25	28	26	33	32
Breaker Size	30 amp	30 amp	30 amp	30 amp	50 amp	50 amp
Watts	6kW	6kW	10kW	11kW	12kW	13kW
NEMA Plug	L6-30P	L6-30P	L15-30P	L15-30P	15-50P	15-50P

Steamer Model "F" Specifications - CE Models ONLY per cavity DBL = TWO CAVITIES				
Model #	S3/S62301F070 DBL	S3/S64005F110 DBL		
Volts AC	230	380	400	415
Phase	1	3	3	3
Amps	32	14	14	15
Breaker Size	40 amp	20 amp	20 amp	20 amp
Watts	7kW	9kW	10kW	11kW
IEC Plug	60309-2 2P/3W/6H 220-250V	60309-2 3P/5W/6H 220/380-240/415V		

Shipping Information	
Shipping Weight Crate 1	208
Shipping Dimensions Crate 1	32 x 36 x 71
Shipping Dimensions Crate 2	208
Shipping Weight Crate 2	32 x 36 x 36
Total Weight Crates 1&2	416

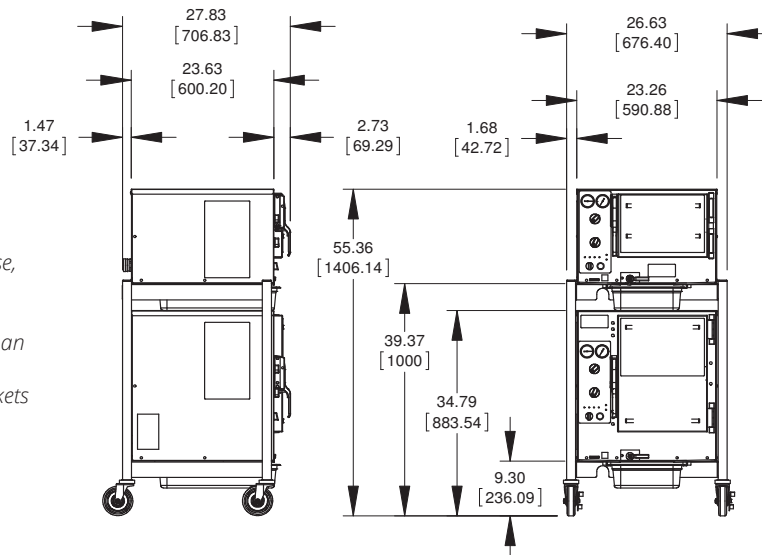
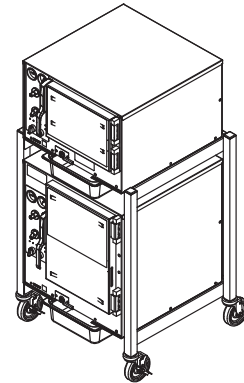
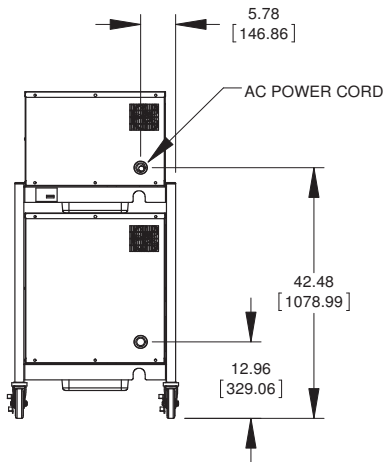

Notes:

1. Allow 3" between fryer, ranges, and other hot surfaces.
2. (2) 5' power cords supplied with single or 3 phase, separate receptacle needed for each unit
3. For use on individual branch circuits only.
4. Do not connect to a circuit operating at more than 150V to ground.
5. Dimensions outside brackets are inches, in brackets are millimeters.