



EVOLUTION™ GAS / PROPANE N6-SERIES PARTS MANUAL



ACCUTEMP PRODUCTS INC
11919 John Adams Dr. New Haven, IN 46774
www.accutemp.net Email: parts@accutemp.net
1-800-480-0415

 **WARNING**

The State of California enacted the California Safe Drinking Water and Toxic Enforcement Act of 1986, (Prop. 65), which “prohibits any person in the course of doing business from knowingly and intentionally exposing any individual to a chemical known to the State of California to cause cancer or reproductive toxicity without first giving clear and reasonable warning to such individuals.”

The Governor’s Scientific Advisory Panel added Carbon Monoxide to the list of hazardous chemicals known to cause reproductive harm.

In order to establish full compliance with Proposition 65, a yellow warning label has been attached to each gas fired unit manufactured by AccuTemp Products, Inc. Carbon monoxide would not be present in concentrations that would pose a “significant risk” to the consumer when the equipment is installed, operated and maintained as follows:

1. Installed in accordance with all local codes, or in the absence of local codes, with the current National Fuel Gas Code Z223.1, latest addenda.
2. Installed under a properly designed and operating exhaust hood.
3. Connected to the type of gas for which the unit is equipped.
4. Proper appliance pressure regulator installed on the gas supply line and adjusted for the manifold pressure marked on the rating plate.
5. Adequate air supply to the unit and adequate clearance around the flue.
6. The equipment is operated in the manner intended using the proper utensil for that type of appliance.
7. Keep the equipment clean and have it checked periodically.
8. Burner air adjustments, mechanical maintenance and repairs should be performed by qualified service personnel.

WARNING SYMBOL DEFINITIONS

SYMBOL DEFINITIONS

Symbols are used to attract your attention to possible dangers. They are only effective if the operator uses proper accident prevention measures. Some of the symbols are boxed text; while others maybe just picture icons. Please give this information the respect they deserve for safe operation.

Symbol Icons

Below are definitions of the symbol icons used in this manual.



DANGER

Indicates an imminently hazardous situation; which, if unchanged, will result in death or serious injury.



CAUTION

Indicates a potentially hazardous situation; which, if unchanged, will result in minor or moderate injury.

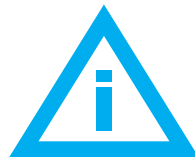

NOTE

Advises the reader of information or instructions, vital to the operation or maintenance of the equipment.



CAUTION - HOT SURFACE



DANGEROUS VOLTAGE

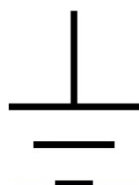

EARTH GROUND

Table of Contents

N6 = 6 Pan Evolution Gas Steamer

Fig: 1.0 N6 Steamer Components - Page 5 & 6

Fig: 1.1 N6 Steamer Components - Page 7 & 8

Fig: 1.2 N6 Steamer Components - Page 9

Fig: 1.3 N6 Steamer Components - Page 10

Fig: 1.4 N6 Steamer Components - Page 11

Fig: 1.5 N6 Water Fill Components - Page 12

Fig: 1.6 N6 Water Drain Components - Page 13

Fig: 1.7 N6 Gas Components - Page 14

Fig: 1.8 N6 Blower Motor Components - Page 15

Fig: 1.9 N6 Burner Box Components - Page 16

Fig: 2.0 N6 Electrical Components - Page 17

Fig: 2.1 N6 Leg Components - Page 18

Fig: 2.2 N6 Door Components - Page 19

Fig: 2.3 N6 Door Components - Page 20

Fig: 2.4 N6 Door Components - Page 21

Quick Reference Parts Sheet - Page 22

Fig 1.0 N6 Common Components

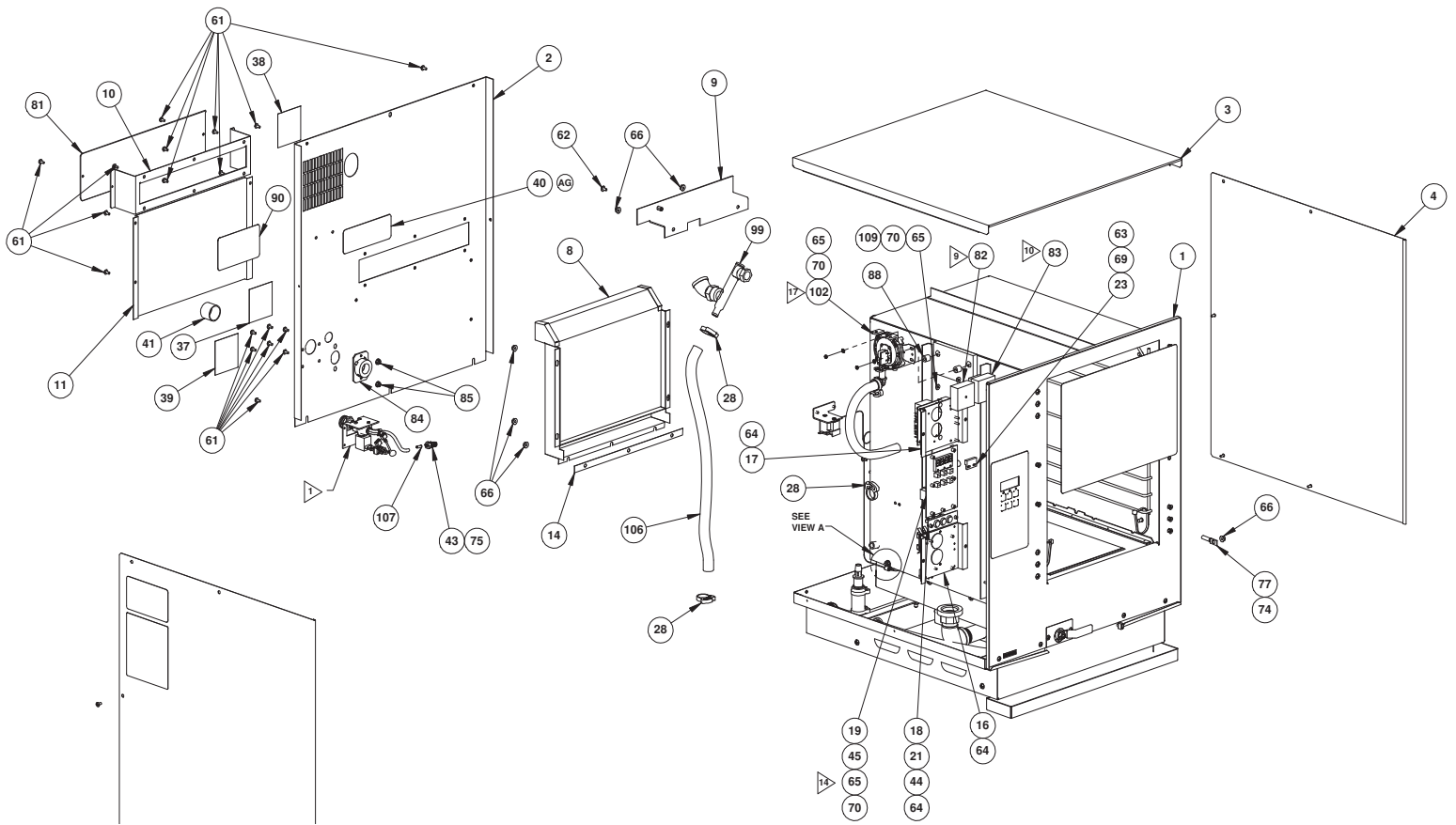

ITEM #	PART NUMBER	DESCRIPTION
#1	AT1A-6633-1	CHAMBER ASSY, 6PAN EVO FOLDED GAS
#2	AT1M-3588-5	PANEL, BACK
#3	AT1A-3629-1	ASSEMBLY, TOP PANEL
#4	AT1M-3587-1	PANEL, SIDE
#8	AT1A-3753-1	FLUE WELDMENT
#9	AT1A-3816-1	BRACKET REAR SUPPORT ASSEMBLY
#10	AT1M-3773-1	BEZEL REAR FLUE
#11	AT1M-3774-1	PANEL SHIELD REAR FLUE
#14	AT1I-3771-3	GASKET, BURNER FRONT
#16	AT1A-3746-1	COMPONENT BRACKET ASSEMBLY
#17	AT1A-3746-2	COMPONENT BRACKET ASSEMBLY
#18	AT1M-3607-1	BRACKET, INDICATOR LAMP
#19	AT0E-6695-1-RXX *	CONTROLLER, QUANTEM SERIES 130
#23	AT0A-3660-1	SENSOR MAGNETIC PROXIMITY ASSY
#28	AT0P-2714-5	HOSE CLAMP 1/2" ID
#37	AT1L-3665-1	LABEL, WATER BACKFLOW
#38	AT1L-3665-2	LABEL, STEAM EXHAUST VENT
#39	AT1L-3665-3	LABEL, GAS INLET CONNECTION
#40	AT1L-6724-1	SUPPLEMENTAL DATA TAG
#41	AT0P-4293-1	CAP, PIPE
#43	AT0P-3495-3	MALE CONNECTOR, 1/4 TUBE TO 1/8
#61	AT0F-1046-31030	SCREW, #8-32 x 3/8 PHLP
#62	AT0F-1046-41030	SCREW, #10-24 x 3/8 PHLP
#63	AT0F-2778-11002	NUT, #4-40UNC-2B ZINC PLATED
#64	AT0F-2691-21002	NUT, #6-32 NYLOC
#65	AT0F-3621-1	NUT, #6-32UNC-2B HEX
#66	AT0F-1017-41002	NUT, #10-24UNC HEX SERRATED

Fig 1.0 N6 Common Components

ITEM #	PART NUMBER	DESCRIPTION
#70	AT0F-2666-21000	WASHER, SS #6 EXTERNAL TOOTH LOCK
#77	AT0E-3626-1	TEMPERATURE SENSOR, RTD
#82	AT0E-2500-1	TIMER RELAY
#83	AT0E-2500-2	TIMER RELAY
#84	AT1A-3878-1	SHAFT COLLAR WELDMENT
#85	AT0F-1017-31002	NUT, #8-32UNC HEX SERRATED
#88	AT1P-2555-32000	HOSE 1/4 ID X 1/2 OD (SOLD PER FOOT)
#90	AT0L-4933-1	LABEL, WARNING, PROPOSITION 65
#99	AT1A-5191-1	STEAMER VENT ASSY
#99-1	AT1A-5093-1	VENT FITTING
#102	AT0E-3617-4	PRESSURE SWITCH
#105	AT0P-3833-63000	HOSE, SILICONE (SOLD PER FOOT)
#106	AT0P-3833-63000	HOSE, SILICONE (SOLD PER FOOT)

***PLEASE CONTACT OUR SERVICE PARTS DEPARTMENT FOR THE MOST CURRENT CONTROLLER SERIES AT0E-6695-1-RXX AT 1-800-480-0415 OR parts@accutemp.net**

Fig 1.1 N6 Common Components

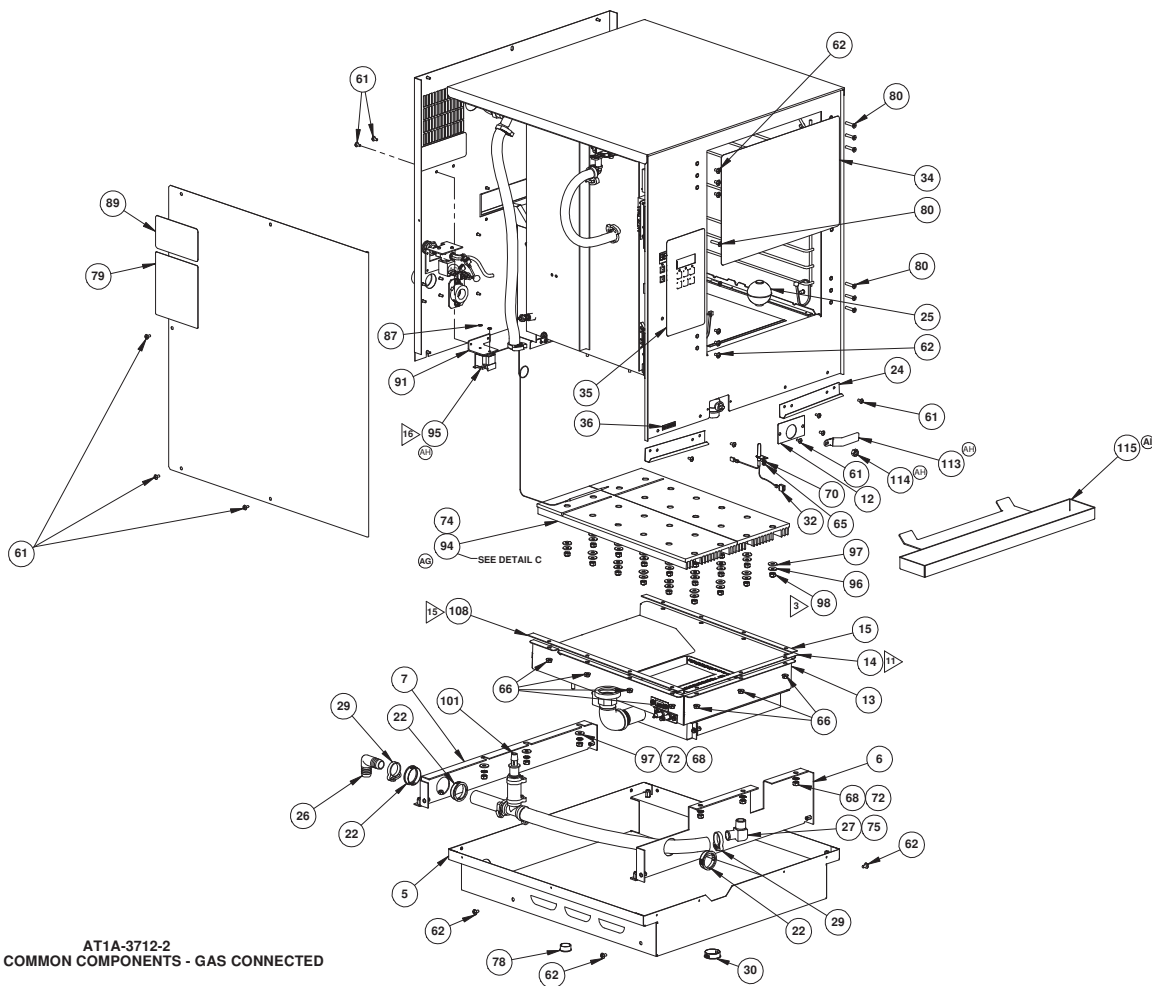

**AT1A-3712-2
MODULE, COMMON COMPONENTS - GAS CONNECTED**

ITEM #	PART NUMBER	DESCRIPTION
#5	AT1A-3757-2	PANEL BOTTOM ASSEMBLY
#6	AT1A-3742-1	BRACKET, FRONT SUPPORT ASSEMBLY
#7	AT1A-3742-3	BRACKET, REAR SUPPORT ASSEMBLY
#12	AT1M-3348-1	COVER, STEAMER DRAIN
#13	AT1Z-6253*	BURNER BOX & BURNER ASSY KIT
#13-1	AT1Z-5475*	BURNER ASSY KIT
#14	AT1I-3771-3	GASKET, BURNER FRONT
#15	AT1I-3771-4	GASKET, BURNER SIDE
#22	AT0H-2576-3	GROMMET, 1½" NYLON
#24	AT1M-2573-3	DRIP EDGE
#25	AT0P-3233-1	FLOAT BALL, ROUND
#26	AT0P-3488-1	ELBOW, 90° HOSE BARB 3/4 X 3/4
#27	AT0P-3481-1	ELBOW, 90° NPT TO BEADED HOSE BARB
#29	AT0P-2714-3	HOSE CLAMP 3/4" ID
#30	AT0H-3643-1	PLUG, DOME 1.25 DIA
#32	AT0A-3519-3	REED SWITCH WIRING HARNESS
#34	AT1L-3658-1	OVERLAY, STEAMER OPERATING INSTRUCTIONS
#35	AT1L-3608-1	OVERLAY, STEAMER CONTROL PANEL
#36	AT1L-3369-1	LABEL, SERIAL NUMBER
#61	AT0F-1046-31030	SCREW, #8-32 x 3/8 PHLP TRUSS
#62	AT0F-1046-41030	SCREW, #10-24 x 3/8 PHLP TRUSS

***PLEASE CONTACT OUR SERVICE PARTS DEPARTMENT FOR THE MOST CURRENT PART NUMBERS AT 1-800-480-0415 OR EMAIL parts@accutemp.net**

Fig 1.1 N6 Common Components

ITEM #	PART NUMBER	DESCRIPTION
#65	ATOF-3621-1	NUT, #6-32UNC-2B UNDERSIZE HEX
#66	ATOF-1017-41002	NUT, #10-24UNC HEX SERRATED
#68	ATOF-2778-51002	NUT, 1/4-20UNC-2B ZINC PLATED HEX
#70	ATOF-2666-21000	WASHER, SS #6 EXTERNAL TOOTH LOCK
#72	ATOF-2666-51005	WASHER, 1/4 410 SS EXTERNAL TOOTH LOCK
#78	AT0H-3643-4	PLUG, DOME .875 DIA
#79	AT0L-2799-1	OVERLAY, WARNING, GAS FIRED GRIDDLE
#80	ATOF-3480-41080	SCREW, #10-24 x 1" DRL SPAN FLT HD MACH
#87	ATOF-2666-30000	WASHER, SS #8 INTERNAL TOOTH LOCK
#89	AT0L-2802-1	OVERLAY, NOTICE, MOBILE APPLIANCE
#91	AT1M-5080-1	BRACKET, BULB OT MNTG
#94	AT1M-6725-1	MACHINED, ALUMINUM EXTRUSION - HEAT TRANSFER
#95	AT0E-6791-1	THERMOSTAT
#96	ATOF-2663-4	WASHER, Ø.687 OD BELLEVILLE
#97	ATOF-1052-51000	WASHER 1/4 TYPE B PLAIN STAINLESS STEEL
#98	ATOF-2676-51003	LOCK NUT, STD FLEX-TOP - 1/4-20
#101	AT1A-5193-2	DRAIN TUBE SUBASSY
#108	AT1I-3771-7	INSULATION
#113	AT0A-6756-1	HANDLE AND COVER ASSEMBLY
#114	ATOF-6729-1	NUT, HEX - M8-1.25, A4-80SS (316)
#115	AT1A-6966-1	GAS CONDENSATE TRAY ASSEMBLY

***PLEASE CONTACT OUR SERVICE PARTS DEPARTMENT FOR THE MOST CURRENT PART NUMBERS AT 1-800-480-0415 OR EMAIL parts@accutemp.net**

Fig 1.2 N6 Common Components

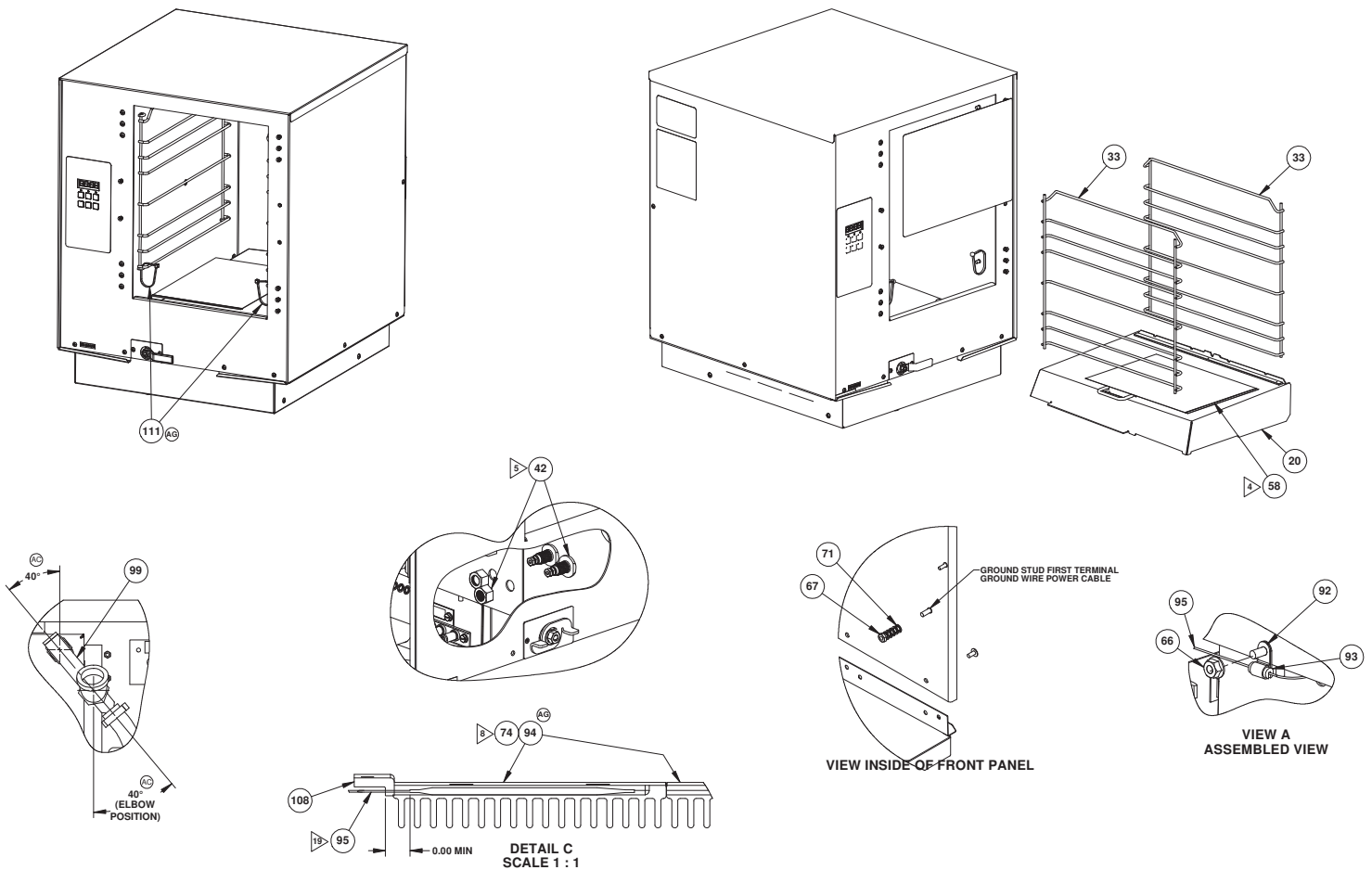

ITEM #	PART NUMBER	DESCRIPTION
#20	AT1A-3663-1	ENCLOSURE, STEAM COLLECTOR ASSEMBLY
#33	AT1A-3601-6	WIRE RACK ASSEMBLY
#42	AT1E-2652-1	PROBE, WATER LEVEL SENSOR
#58	AT1A-3387-3	LOOSE PIECES, STEAMER
#66	ATOF-1017-41002	NUT, #10-24UNC HEX SERRATED
#67	ATOF-2778-41001	NUT, #10-24UNC-2B SS HEX MACHINE SCREW
#71	ATOF-2666-40000	WASHER, SS #10 INTERNAL TOOTH LOCK
#92	AT0H-5169-3	CLAMP, CABLE - 1/4 DIA
#93	AT1M-5171-1	U-CHANNEL, INSULATING
#94	AT1M-6725-1	MACHINED, ALUMINUM EXTRUSION - HEAT TRANSFER
#95	ATOE-6791-1	THERMOSTAT
#99	AT1A-5191-1	VENT ASSY, STEAMER
#99-1	AT1A-5093-1	VENT FITTING
#111	ATOE-2580-1	4" CABLE TIE

***PLEASE CONTACT OUR SERVICE PARTS DEPARTMENT FOR THE MOST CURRENT PART NUMBERS AT 1-800-480-0415 OR EMAIL parts@accutemp.net**

Fig 1.3 N6 Common Components

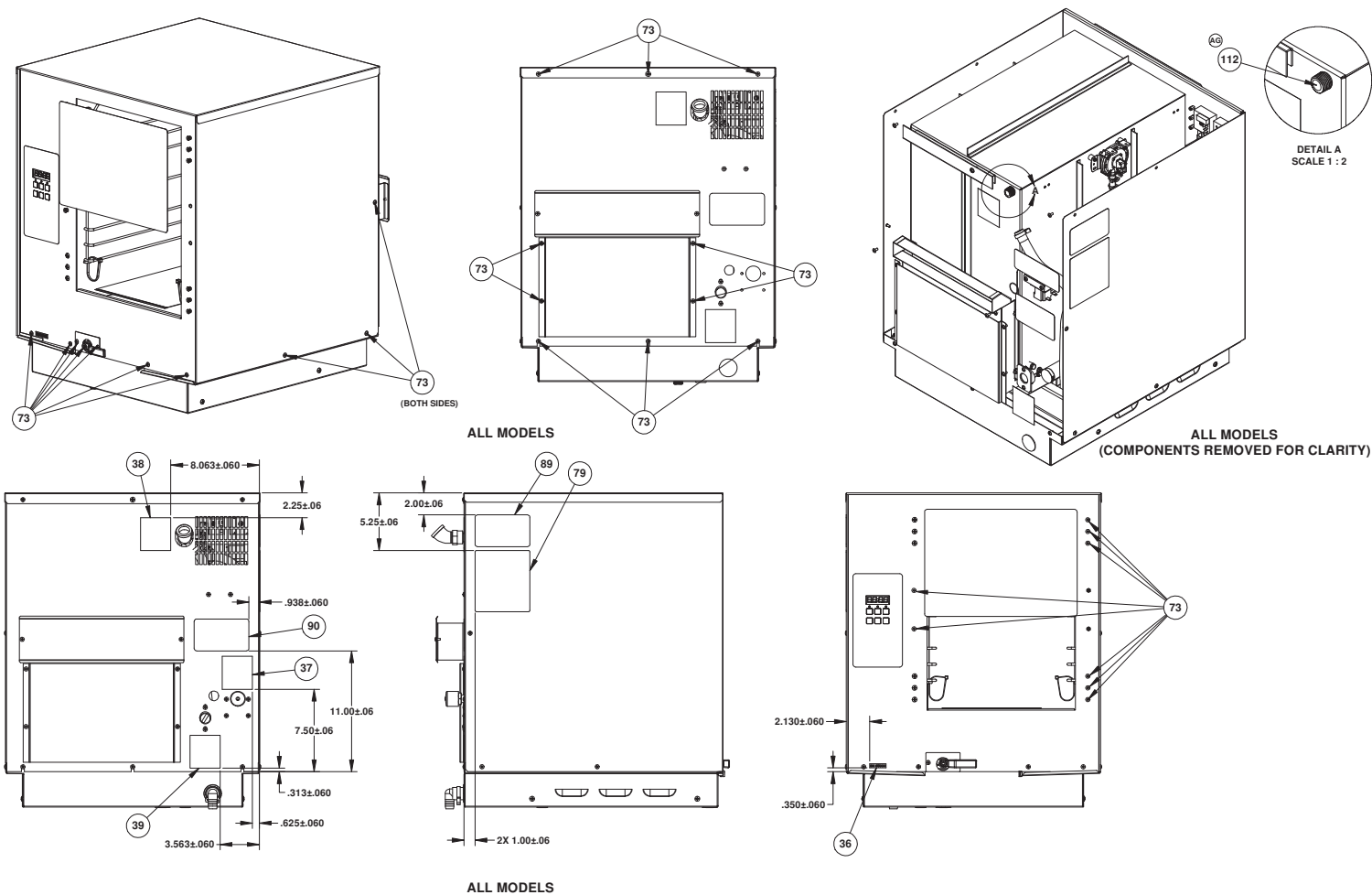

ITEM #	PART NUMBER	DESCRIPTION
#36	AT1L-3369-1	LABEL, SERIAL NUMBER
#37	AT1L-3665-1	LABEL, WATER BACKFLOW
#38	AT1L-3665-2	LABEL, STEAM EXHAUST VENT
#39	AT1L-3665-3	LABEL, GAS INLET CONNECTION
#73	AT0H-3065-3	THREAD LOCKER 248
#79	AT0L-2799-1	OVERLAY, WARNING, GAS FIRED GRIDDLE
#89	AT0L-2802-1	OVERLAY, NOTICE, MOBILE APPLIANCE
#90	AT0L-4933-1	LABEL, WARNING, PROPOSITION 65
#112	AT0P-3063-1	1/4" TEFLON TAPE

***PLEASE CONTACT OUR SERVICE PARTS DEPARTMENT FOR THE MOST CURRENT PART NUMBERS AT 1-800-480-0415 OR EMAIL parts@accutemp.net**

Fig 1.4 N6 Common Components

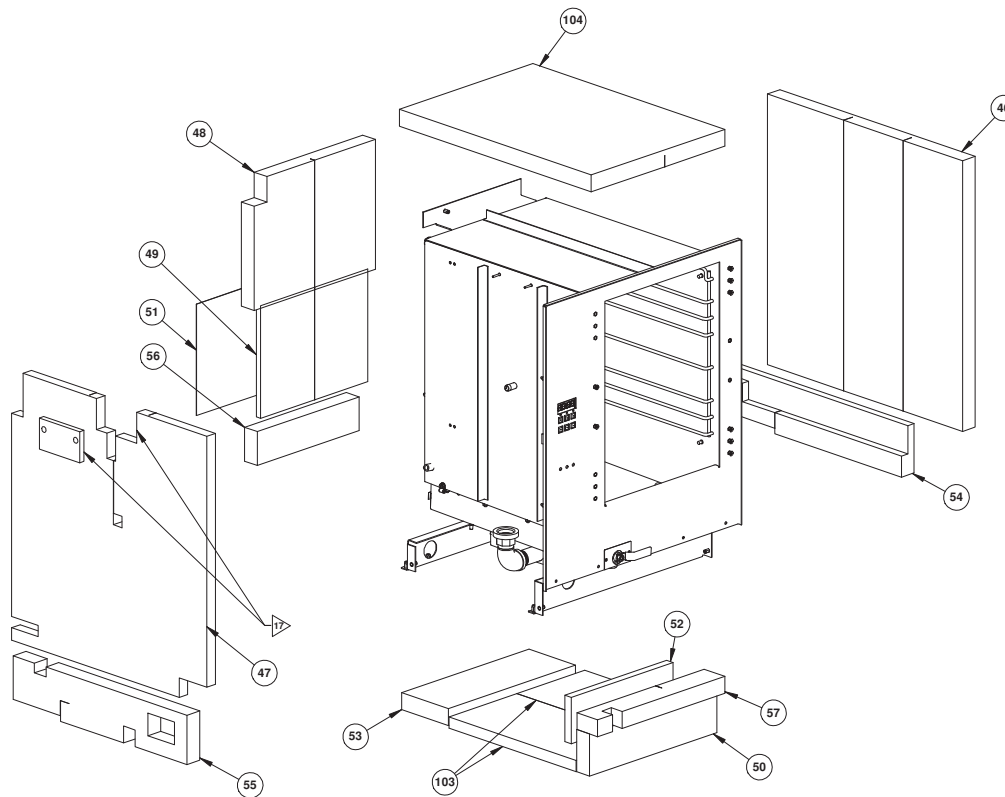

ITEM #	PART NUMBER	DESCRIPTION
#46	AT1I-2866-23	INSULATION, RIGHT SIDE
#47	AT1I-2866-32	INSULATION, LEFT SIDE WALLS
#48	AT1I-2866-34	INSULATION, REAR TOP
#49	AT1I-2866-35	INSULATION, REAR BOTTOM FRONT
#50	AT1I-2866-2	INSULATION, STEAMER
#51	AT1I-3771-5	INSULATION CERAMIC FIBER PAPER REAR FLUE BACK
#52	AT0I-3799-1	INSULATION THERMAL CERAMIC BACK FRONT BRKT
#53	AT0I-3799-2	INSULATION THERMAL CERAMIC BOTTOM BACK
#54	AT0I-3799-3	INSULATION THERMAL CERAMIC RIGHT SIDE
#55	AT0I-3799-4	INSULATION THERMAL CERAMIC LEFT SIDE
#56	AT0I-3799-5	INSULATION THERMAL CERAMIC REAR BOTTOM
#57	AT0I-3799-6	INSULATION THERMAL CERAMIC BOTTOM FRONT
#103	AT1I-2866-64	INSULATION, STEAMER
#104	AT1I-2866-71	INSULATION, TOP

***PLEASE CONTACT OUR SERVICE PARTS DEPARTMENT FOR THE MOST CURRENT PART NUMBERS AT 1-800-480-0415 OR EMAIL parts@accutemp.net**

Fig 1.5 N6 Water Fill Components

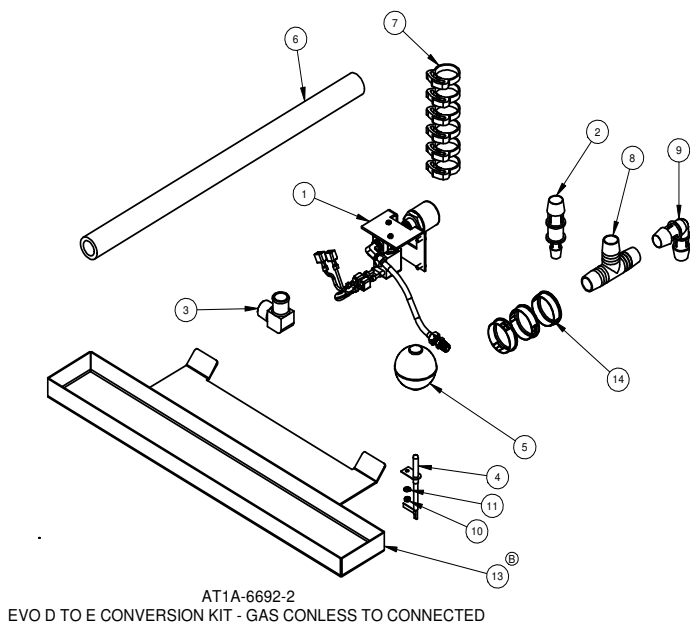

ITEM #	PART NUMBER	DESCRIPTION
#1	AT1A-5220-1	KIT, WATER VALVE
#1-1	AT1A-5185-1	WATER FILL SOLENOID
#2	ATOP-5180-1	HOSE BARB 3/4" TO 1/2", REDUCTION COUPLER
#3	ATOP-3481-1	ELBOW, 90° NPT TO BEADED HOSE BARB
#4	AT0E-3234-1	SENSOR, MAGNETIC REED SWITCH
#5	ATOP-3233-1	FLOAT BALL, ROUND
#6	ATOP-3477-83000	3/4" HOSE, SILICONE (SOLD PER FOOT)
#7	ATOP-2714-3	HOSE CLAMP 3/4" ID
#8	ATOP-2987-3	BARBED TEE FITTING, 3/4 X 3/4 X 3/4
#9	ATOP-3488-1	ELBOW, 90° HOSE BARB 3/4 X 3/4
#10	ATOF-3621-1	NUT, #6-32UNC-2B UNDERSIZE HEX
#11	ATOF-2666-21000	WASHER, SS #6 EXTERNAL TOOTH LOCK
#13	AT1A-6966-1	GAS CONDENSATE TRAY ASSEMBLY
#14	AT0H-2576-3	GROMMET, 1 1/2" NYLON

***PLEASE CONTACT OUR SERVICE PARTS DEPARTMENT FOR THE MOST CURRENT PART NUMBERS AT 1-800-480-0415 OR EMAIL parts@accutemp.net**

Fig 1.6 N6 Water Drain Components

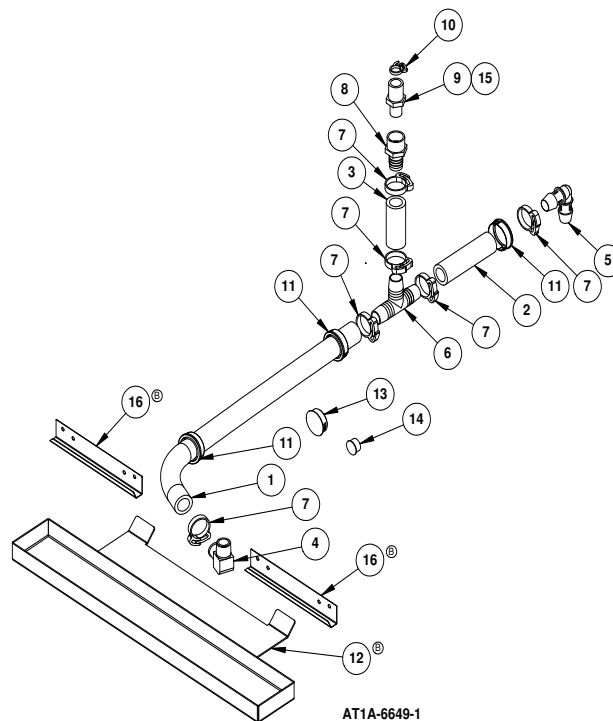

ITEM #	PART NUMBER	DESCRIPTION
#1	ATOP-3477-83210	3/4" HOSE, SILICONE (SOLD PER FOOT)
#2	ATOP-3477-83210	3/4" HOSE, SILICONE (SOLD PER FOOT)
#3	ATOP-3477-83210	3/4" HOSE, SILICONE (SOLD PER FOOT)
#4	ATOP-3481-1	ELBOW, 90° NPT TO BEADED HOSE BARB
#5	ATOP-3488-1	ELBOW, 90° HOSE BARB 3/4 X 3/4
#6	ATOP-2987-3	BARBED TEE FITTING, 3/4 X 3/4 X 3/4
#7	ATOP-2714-3	HOSE CLAMP 3/4" ID
#8	ATOP-5216-1	HOSE BARB, 1/2 FNPT X 3/4
#9	ATOP-5217-1	NIPPLE, 1/2 X 3/8 NPT REDUCING
#10	ATOP-2714-7	HOSE CLAMP .500+ O.D. HOSE
#11	ATOH-2576-3	GROMMET, 1½" NYLON
#12	AT1A-6966-1	GAS CONDENSATE TRAY ASSEMBLY
#13	ATOH-3643-1	PLUG, DOME 1.25 DIA
#14	ATOH-3643-3	PLUG, DOME .687 DIA
#16	AT1M-2573-3	DRIP EDGE

***PLEASE CONTACT OUR SERVICE PARTS DEPARTMENT FOR THE MOST CURRENT PART NUMBERS AT 1-800-480-0415 OR EMAIL parts@accutemp.net**

Fig 1.7 N6 Gas Components

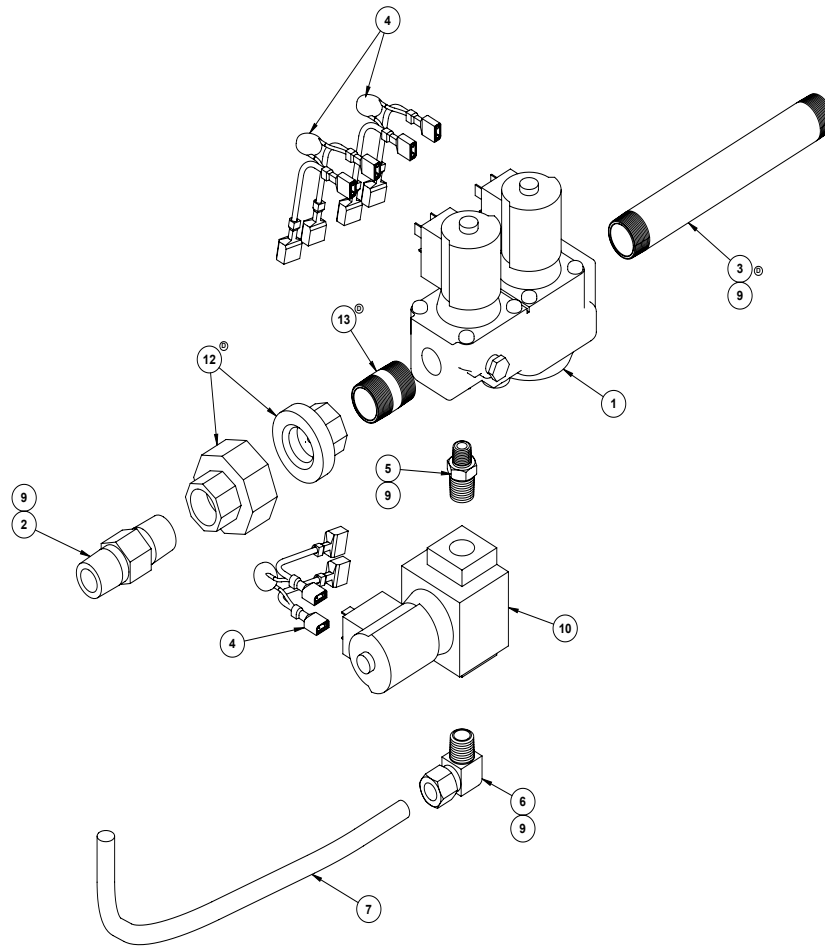

ITEM #	PART NUMBER	DESCRIPTION
#1	AT2E-1806-2	CONTROL VALVE, GAS 5" W.C. NG S/N: 71309 & LOWER
#1-1	AT2E-1806-4	CONTROL VALVE, GAS 3.5" W.C. NG S/N: 71310 & HIGHER
#1-2	AT2E-1806-3	CONTROL VALVE, GAS 10" W.C. PROPANE GAS
#2	AT0B-3758-1	ORIFICE, GAS STEAMER
#2-1	AT0B-3758-12	ORIFICE, PROPANE STEAMER
#3	AT0P-3567-32060	NIPPLE, 6" x 1/2" NPT, BLACK IRON
#4	AT0A-2736-9	MOV- TERMINALS ASSEMBLY 36V
#5	AT0P-2848-1	REDUCING HEX NIPPLE
#6	AT0P-2096-2	ELBOW 90° 1/4 NPT TO 3/8 TUBE
#7	AT2P-2104-1	TUBING, CORRUGATED COMPRESSION FITTING
#9	AT0H-3102-1	PIPE THREAD SEALANT
#10	AT0P-3818-1	VALVE, SOLENOID GAS SHUTOFF
#12	AT0P-2843-1	UNION BLACK IRON
#13	AT0P-3567-32000	NIPPLE, CLOSE, BLACK IRON-1/2" NPT

***PLEASE CONTACT OUR SERVICE PARTS DEPARTMENT FOR THE MOST CURRENT PART NUMBERS AT 1-800-480-0415 OR EMAIL parts@accutemp.net**

Fig 1.8 N6 Blower Motor Components

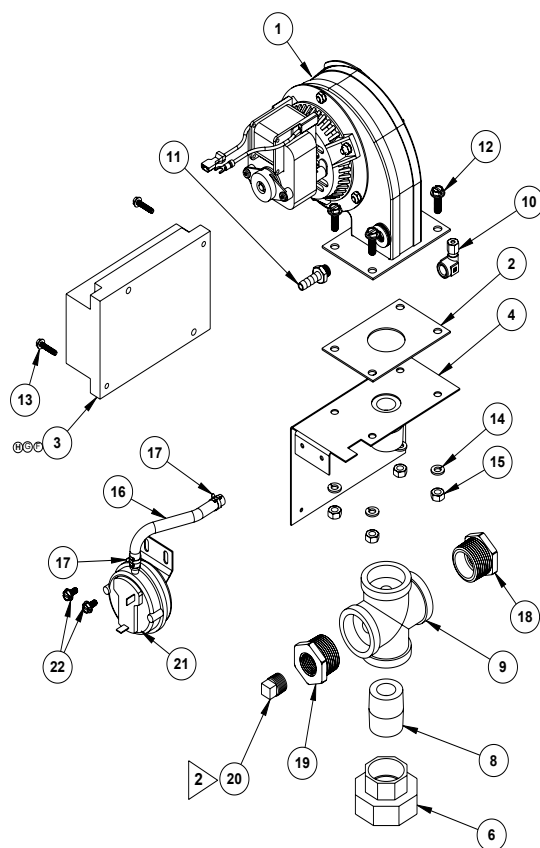

ITEM #	PART NUMBER	DESCRIPTION
#1	AT0E-3759-1	BLOWER MOTOR ASSY
#3	AT0E-3760-3	AUTO INGITION MODULE FENWAL
#3-1	AT0E-6694-1	AUTO INGITION MODULE BASO
#4	AT1A-3744-1	BRACKET, BLOWER MTG ASSEMBLY
#6	AT0P-2843-2	UNION BLACK IRON
#8	AT2P-2465-3	PIPE, 1" NPT CLOSE NIPPLE
#9	AT0P-2844-2	CROSS, 1" NPT SCH 40
#10	AT0P-3762-1	ELBOW, FEMALE
#11	AT0P-2618-5	FITTING, 1/8" NPT TO 1/4" HOSE BARB
#12	CALL ACCUTEMP	SCREW, 1/4-20 X 3/4" LG FLANGED, SLOTTED HEX
#13	CALL ACCUTEMP	SCREW, #8-32 X 3/4" LG FLANGED, SLOTTED HEX
#14	AT0F-1922-50000	WASHER, 1/4" HELICAL SPRING LOCK
#15	AT0F-2778-51000	NUT, 1/4-20UNC-2B SS HEX MACHINE SCREW
#16	AT0P-3833-6300	1/2" SILICONE HOSE (SOLD PER FOOT)
#17	AT0P-2714-5	1/2" HOSE CLAMP
#18	AT0P-3817-1	1" X 1/2" HEX BUSHING
#19	AT0P-3817-2	1" X 3/8" HEX BUSHING
#20	AT0P-3822-1	PLUG, 3/8 NPT SQUARE HEAD PIPE
#21	AT0E-3617-3	SWITCH, AIR PRESSURE
#22	CALL ACCUTEMP	SCREW, #10-32 X 3/8" LG FLANGED, SLOTTED HEX

***PLEASE CONTACT OUR SERVICE PARTS DEPARTMENT FOR THE MOST CURRENT PART NUMBERS AT 1-800-480-0415 OR EMAIL parts@accutemp.net**

Fig 1.9 N6 Burner Box Components

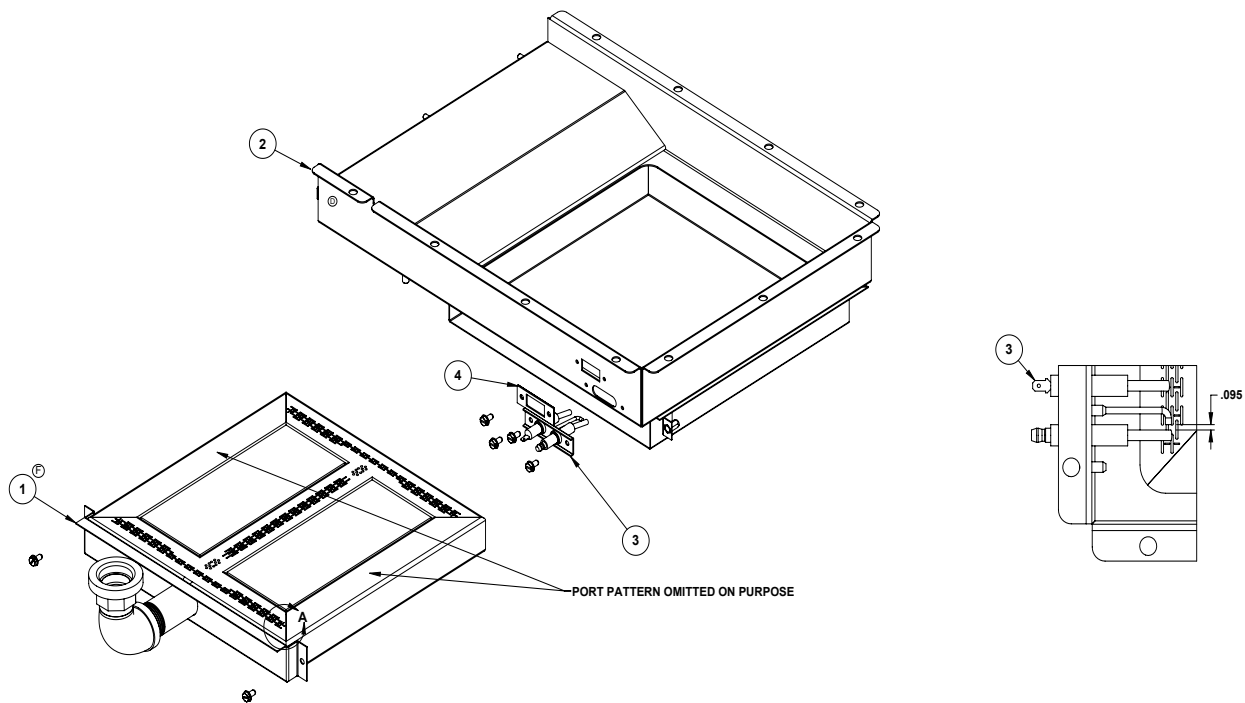

1	AT1M-3796-1
---	-------------

ITEM #	PART NUMBER	DESCRIPTION
#1	AT1A-6124-1	BURNER ASSEMBLY, GAS STEAMER
#2	AT1A-3769-1	COMBUSTION BOX WELDMENT
#3	AT1E-3795-1	IGNITOR/SENSOR PROBE ASSEMBLY
#4	AT1M-3796-1	SIGHT GLASS AND HOLDER

***PLEASE CONTACT OUR SERVICE PARTS DEPARTMENT FOR THE MOST CURRENT PART NUMBERS AT 1-800-480-0415 OR EMAIL parts@accutemp.net**

Fig 2.0 N6 Electrical Components

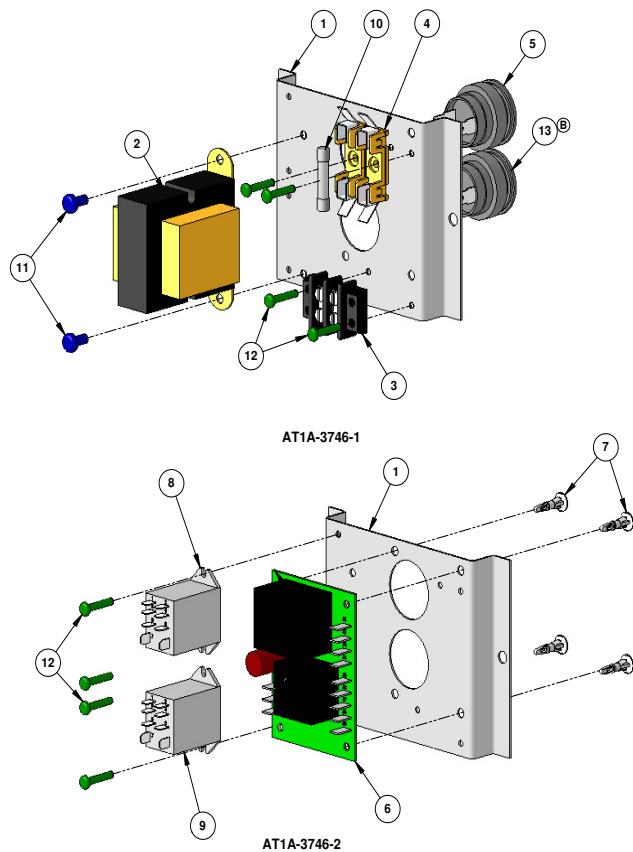

ITEM #	PART NUMBER	DESCRIPTION
#1	AT1M-3747-1	BRACKET, COMPONENT MTG
#2	AT0A-2779-3	TRANSFORMER ASSEMBLY
#3	AT0E-1134-2	2 POSITION TERMINAL BLOCK
#4	AT0E-2708-1	3AG OMNI-BLOK FUSE BLOCK 2 POS
#5	AT0E-3654-1	DC ALARM, PIEZO ELECTRIC 5-15V
#6	AT0E-3230-2	PCB, DUAL PURPOSE WATER SENSOR
#7	AT0H-3407-1	C B SUPPORT, REVERSE MT'G.
#8	AT0E-2825-5	AC GENERAL PURPOSE RELAY 24V
#9	AT0E-2825-6	DC GENERAL PURPOSE RELAY 24V
#10	AT0E-2731-1	FUSE 3 AMP 250V
#11	AT0F-3620-40032	SCREW, #10-32UNF X 3/8" SWAGEFORM PHILLIPS
#12	AT0F-3620-21052	SCREW, #6-32UNC X 5/8" SWAGEFORM PHILLIPS
#13	AT0E-3654-2	AC ALARM, PIEZO ELECTRIC 5-24V

***PLEASE CONTACT OUR SERVICE PARTS DEPARTMENT FOR THE MOST CURRENT PART NUMBERS AT 1-800-480-0415 OR EMAIL parts@accutemp.net**

Fig 2.1 N6 Leg Components

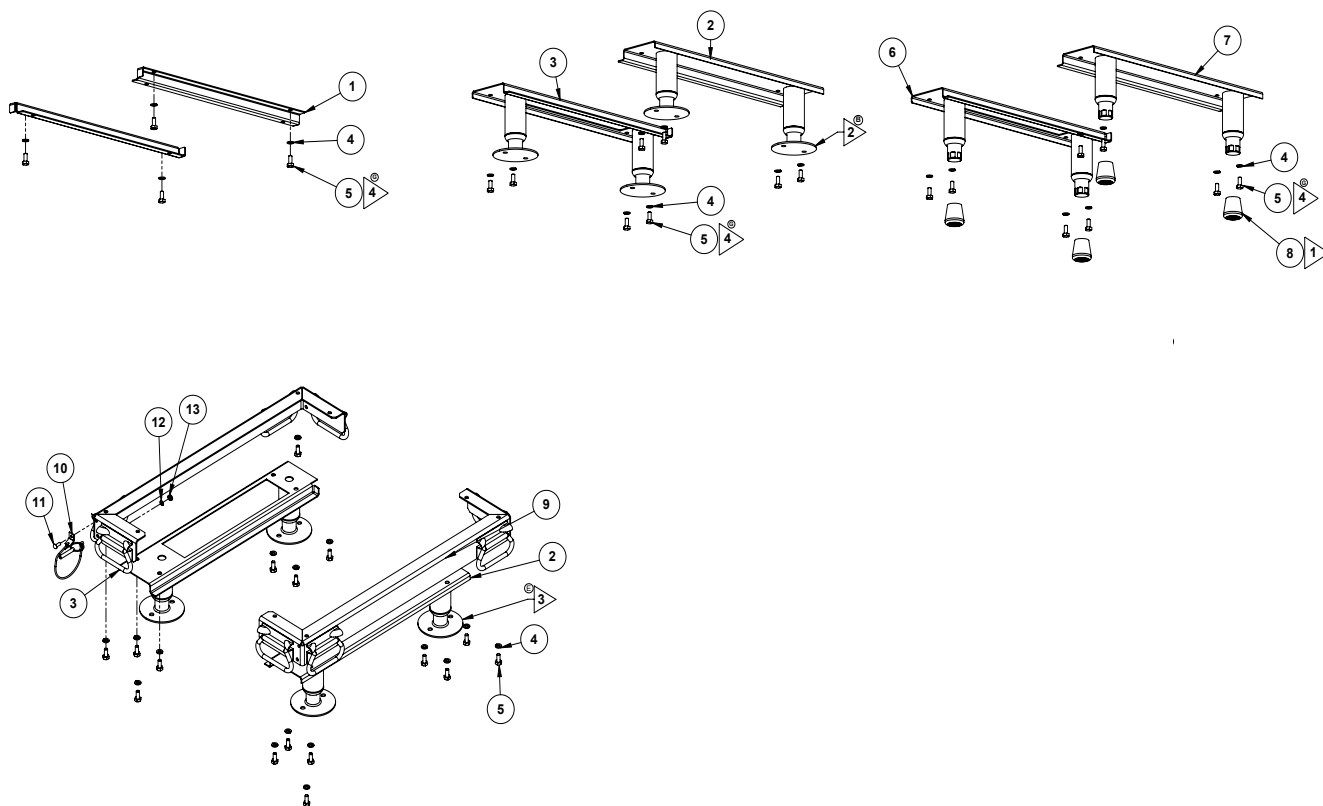

ITEM #	PART NUMBER	DESCRIPTION
#1	AT1M-2872-1	DRAIN PAN BRACKET
#2	AT1A-3038-4	LEG BASE FLANGE RIGHT ASSEMBLY
#3	AT1A-3038-5	LEG BASE FLANGE LEFT ASSEMBLY
#4	ATOF-1922-50000	WASHER, 1/4" HELICAL SPRING LOCK
#5	ATOF-2875-51050	SCREW, 1/4-20UNC X 5/8 HEX HEAD MACHINE
#5-1	ATOF-3448-51066	SCREW, 1/4-20 X 3/4" DRL SPAN PAN HD MACH
#6	AT1A-3038-2	LEG BASE LEFT ASSEMBLY
#6-1	AT1A-3038-10	LEG BASE LEFT ASSEMBLY
#7	AT1A-3038-1	LEG BASE RIGHT ASSEMBLY
#7-1	AT1A-3038-9	LEG BASE RIGHT ASSEMBLY
#8	ATOH-3040-1	RUBBER BULLET FOOT TIP
#9	AT1A-3717-1	ASSEMBLY, LIFTING BRACKET
#10	ATOH-3783-1	PIN, SAFETY LATCHING W/LANYARD
#11	ATOF-2755-41040	SCREW, #10-24UNC X 1/2 PHILIPS
#12	ATOF-2666-40000	WASHER, #10 INTERNAL TOOTH LOCK
#13	ATOF-2778-41001	NUT, #10-24UNC-2B SS HEX MACHINE SCREW

***PLEASE CONTACT OUR SERVICE PARTS DEPARTMENT FOR THE MOST CURRENT PART NUMBERS AT 1-800-480-0415 OR EMAIL parts@accutemp.net**

Fig 2.2 N6 Door Components

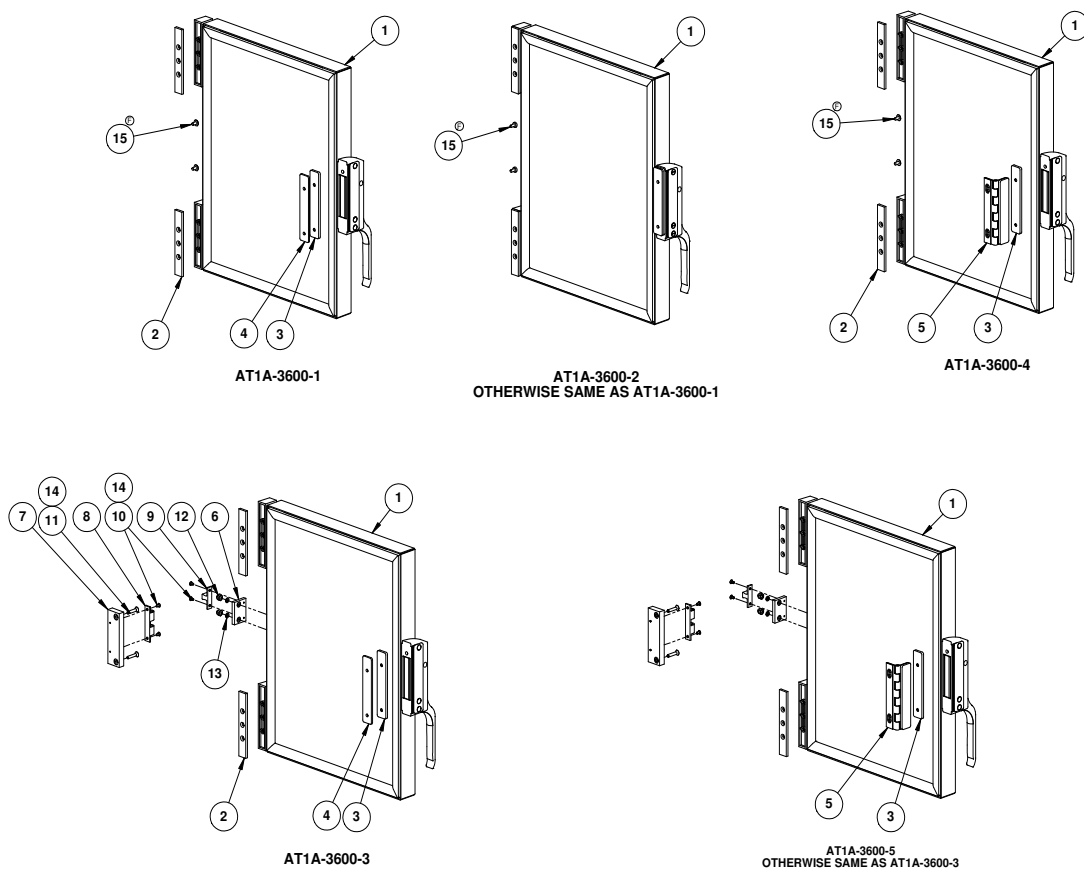

ITEM #	PART NUMBER	DESCRIPTION
#1	AT1A-3645-X	DOOR ASSEMBLY*
#1-1	AT1G-2633-1	GASKET; DOOR
#1-2	AT1A-3647-1	INNER DOOR ASSY W/ GASKET
#1-3	AT1H-3609-1	EVOLUTION DOOR HANDLE ASSY
#1-4	ATOF-2061-41140	SCREWS, DOOR HANDLE 10-24 x 1-3/4"
#1-5	ATOF-2691-41011	LOCKNUTS, DOOR HANDLE 10-24
#1-6	AT1L-3658-1	DOOR DECAL
#2	AT1M-3655-1	SPACER HINGE
#3	AT1H-3609-H	LATCH - STRIKE
#4	AT1H-3609-J	LATCH - SPACER
#5	AT1A-3442-1	CRACK OPEN HINGE ASSEMBLY
#6	AT1M-3671-1	PLATE, HOLD OPEN DOOR
#7	AT1M-3670-1	PLATE, HOLD OPEN FRONT
#8	ATOH-3443-2	CATCH, BALL-STYLE GRAB
#9	ATOH-3443-3	CATCH, BALL-STYLE GRAB
#10	ATOF-2061-21020	SCREW, 6-32 X 1/4" FLAT HEAD MACHINE
#11	ATOF-2061-41080	SCREW, 10-24 x 1" FLAT HD MACHINE
#12	ATOF-2632-41001	NUT, 10-24 ACORN
#13	ATOF-1922-40000	WASHER, 10 SS HELICAL SPRING LOCK
#14	ATOH-3065-3	THREAD LOCKER 248
#15	ATOF-1046-41030	SCREW, 10-24 x 3/8 PHLP TRUSS HEAD
#15-1	ATOF-3448-41036	SCREW, 10-24x3/8" TAMPER PROOF

* PLEASE CALL SERVICE PARTS DEPT FOR CORRECT DOOR CONFIGURATION AT 1-800-480-0415 OR EMAIL parts@accutemp.net

Fig 2.3 N6 Door Components

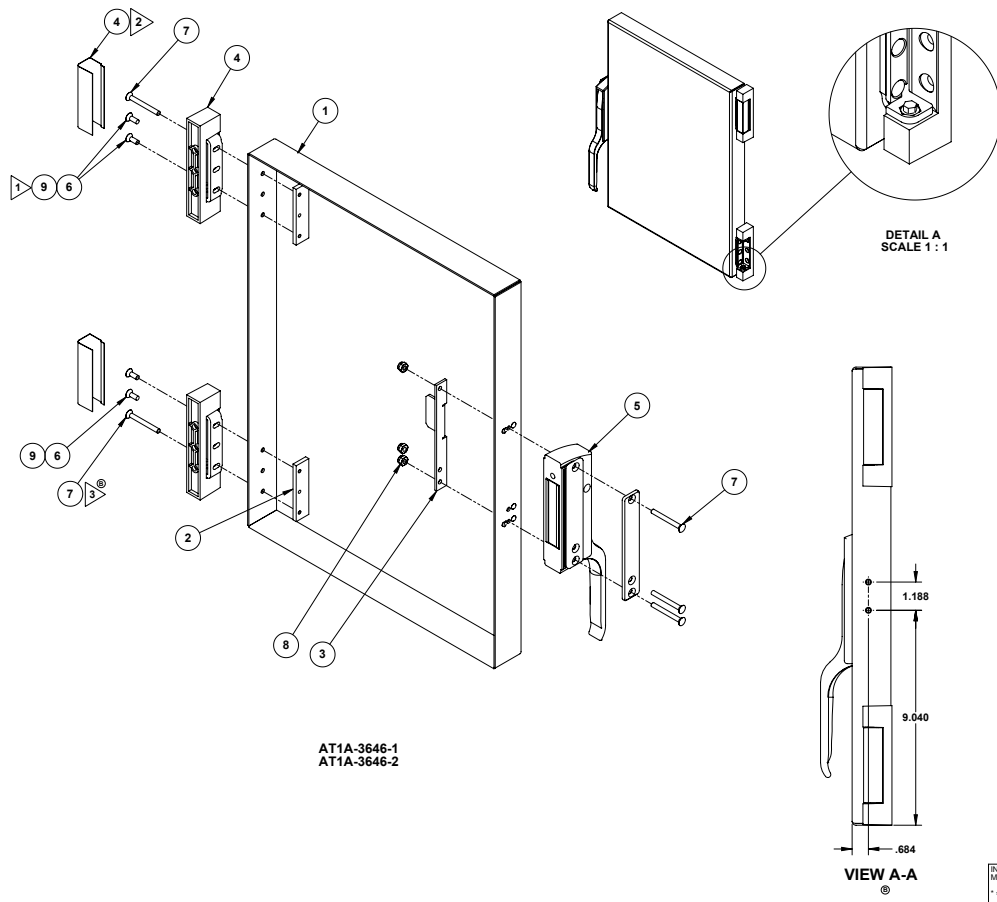

ITEM #	PART NUMBER	DESCRIPTION
#1	AT1M-3648-1	OUTER DOOR PANEL
#2	AT1M-2689-1	HINGE MOUNTING PLATE
#3	AT1M-3046-1	LATCH MOUNTING PLATE RIGHT HAND
#4	AT1H-2058-3	HINGE, STEAMER DOOR (PAIR)
#5	AT1H-3609-1	LATCH HANDLE ASSEMBLY
#6	AT0F-2061-41060	SCREW, 10-24 x 3/4" FLAT HD MACHINE
#6-1	AT0F-3480-41066	SCREW, 10-24 x 3/4" TAMPER PROOF
#7	AT0F-2061-41140	SCREW, 10-24 x 1 3/4" FLAT HD MACHINE
#7-1	AT0F-3480-41166	SCREW, #10-24 x 2" TAMPER PROOF
#8	AT0F-2691-41011	NUT, 10-24 WAXED NYLOC
#9	AT0H-3065-3	THREAD LOCKER 248
#10	AT0F-1016-41040	10-24 x 1/2 FL STUD THD

***PLEASE CONTACT OUR SERVICE PARTS DEPARTMENT FOR THE MOST CURRENT PART NUMBERS AT 1-800-480-0415 OR EMAIL parts@accutemp.net**

Fig 2.4 N6 Door Components

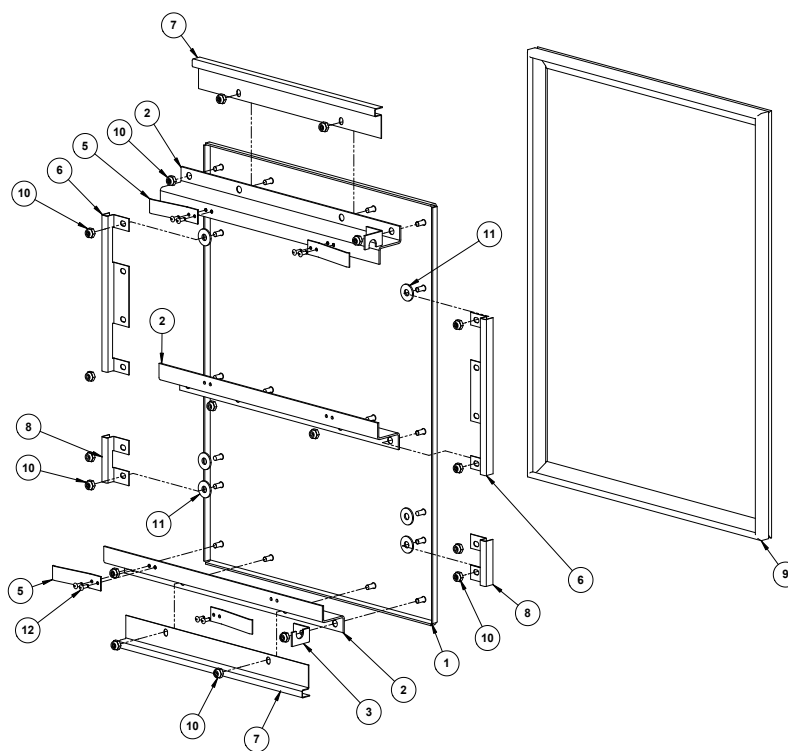

AT1A-3647-1

ITEM #	PART NUMBER	DESCRIPTION
#1	AT1A-3649-1	PANEL, INNER DOOR WELDMENT
#2	AT1M-3651-1 Z	BRACKET, INNER DOOR
#3	AT1M-3466-1	BRACKET, DOOR
#4	AT1M-3466-2	BRACKET, DOOR
#5	AT1M-3653-1	SPRING, INNER DOOR
#6	AT1M-3524-1	RETAINER, SIDE DOOR GASKET
#7	AT1M-3652-1	RETAINER, DOOR GASKET
#8	AT1M-3507-1	RETAINER, SIDE SMALL DOOR GASKET
#9	AT1G-2633-1	INNER DOOR GASKET (6 PAN)
#10	AT0F-2691-41011	NUT, #10-24 WAXED NYLOC
#11	AT0F-1052-51000	WASHER 1/4 TYPE B PLAIN
#12	AT0F-3368-2	BLIND RIVET

***PLEASE CONTACT OUR SERVICE PARTS DEPARTMENT FOR THE MOST CURRENT PART NUMBERS AT 1-800-480-0415 OR EMAIL parts@accutemp.net**

Fig 2.5 N6 Parts Quick Reference

N6 = 6 Pan Evolution Gas/Propane Steamer

AT1G-2633-1	N6 Series Door Gasket
AT1G-3669-1	N6 Series Panel Distribution Gasket
AT1H-3609-1	N6 Evolution Door Handle Assy
AT0F-2061-41140	Door Handle Screws (Qty: 3) Standard
AT1H-2058-3	Door Hinges (Brass) Sold as a Pair
AT0A-3660-1	Door Magnetic Proximity Switch
AT0H-3656-1	Threaded Knob for Distribution Panels
AT1A-3601-6	N6 Standard Wire Rack (Sold as Each)
AT1A-3155-1	Drain Pan w/ Drain Hose Fitting
AT1M-2872-1	Drain Pan Brackets
AT0P-3811-1	45 Degree Steam Exhaust Fitting
AT0E-3162-1	Fuse 1/2 AMP 250V Fast Acting
AT0E-2731-1	Fuse 3 AMP 250V
AT1P-2555-32000	1/4" Silicone Hose - Sold Per Foot
AT0P-3833-63000	1/2" Silicone Hose - Sold Per Foot
AT0P-3477-83000	3/4" Blue Drain Hose - Sold Per Foot
AT0P-2714-1	Hose Clamp 1/4"
AT0P-2714-5	Hose Clamp 1/2"
AT0P-2713-3	Hose Clamp 3/4"
AT0P-2713-4	Hose Clamp; Double Teeth 1" (Autofill Only)
AT1A-3030-1	Leg Assembly Kit, Steamer
AT0H-3040-1	Rubber Foot Tip
AT0H-2479-7	Stand Caster Wheel, No-Brake Foot Lever Qty: 2 for Rear Legs
AT0H-2479-8	Stand Caster Wheels w/ Brake Foot Lever Qty: 2 for Front Legs
AT0E-3617-4	Air Pressure Switch EVO
AT1L-3608-1	Control Panel Overlay
AT0E-3654-2	AC Piezo Electric Alarm (WATER CONTROL BOARD)
AT0E-3654-1	DC Piezo Electric Alarm (CONTROLLER BOARD)
AT1A-6931-1	Ball Valve Handle Assy (Drain Valve)
AT1A-6649-3	Drain Hose Kit w/ Condensation Pan
AT1A-6649-4	Drain Hose Kit
AT1E-2652-1	Probe Water Sensor (Round White Plastic)
AT0E-3230-2	Water Level Circuit Control Board EVO 24V
AT0P-3233-1	Float Ball (56 grams)
AT0A-3519-3	Magnetic Reed Switch w/ Red Terminals

***PLEASE CONTACT OUR SERVICE PARTS DEPARTMENT FOR THE MOST CURRENT PART NUMBERS AT 1-800-480-0415 OR EMAIL parts@accutemp.net**



LIFETIMETM
SERVICE & SUPPORT
1-800-480-0415 | service@accutemp.net