

Project: _____ Location: _____ Item #: _____ Quantity: _____

Short Specification

XLR8™ Heavy duty upper heated platen for mounting on any AccuSteam™ 24" cooking depth griddle. XLR8™ features all stainless-steel construction to maximize strength and longevity. The XLR8™ utilizes proprietary electric heating technology to deliver ±10 degree temperature accuracy and near instant recovery, of set point temperature. Digital controls feature a temperature range from 150°- 440°F. XLR8™ controller also features 2-dual stage timers with automatic timing functionality. Robust single hand lift mechanism with top and bottom detent to ensure positive stops. Adjustable gapping and magnetic Teflon hold down handles. Upper platen coverage dimensions 10.5" x 22.53" deep for maximum zone coverage. Mounting bracket required for installation. 208/240V 50/60Hz single phase.

Performance Features

The XLR8™ proprietary electric heating technology ensures maximum performance no matter the application. With its even temperatures and near instant recovery, the XLR8™ outperforms all the competition with faster cook times, more consistent product quality and improved product safety.

Safety, Sanitation & Environmental



MADE IN USA



NSF/ANSI 4

Standard Control Features

- All stainless-steel construction
- Proprietary electric technology provides even heat and near instant recovery
- Single hand lift mechanism with positive top and bottom detents to ensure smooth operation and positive stops
- Temperature Range from 150°- 440°F
- 2-dual stage timers with automatic timing functionality
- Includes 5 non-proprietary Teflon sheets per arm
- Magnetic Teflon hold down handles
- Dual voltage 208/240V 50/60Hz single phase (max 12 amp draw per arm)
- Easy to use gap adjuster
- One Year Parts and Labor Warranty
- Upper platen coverage dimensions are 10.5" wide x 22.53" deep

Required Options

MOUNTING KIT -

XLR8™ mounts to any natural gas or electric AccuSteam™ griddle featuring a 24" depth ("B depth"). Mounting Bracket allows for flexibility of mounting arms every 12" in any configuration.

Mounting Bracket Kit:

- AT2A-7089-1 24" Electric Kit
- AT2A-7170-1 36" Electric Kit
- AT2A-7170-2 48" Electric Kit
- AT2A-7089-4 24" Gas Kit
- AT2A-7170-3 36" Gas Kit
- AT2A-7170-4 48" Gas Kit

STABILIZATION KIT -

Stand Brace is required for Stand Mounted Griddles.

- AT2A-6882-1 - Stand Stabilizer Brace Assembly



(1) XLR8 arm shown mounted on 24" stand-mounted griddle with required Stand Stabilizer Brace.

Options & Accessories

- AT0H-5661-5 - Teflon Sheets, 10 Pack

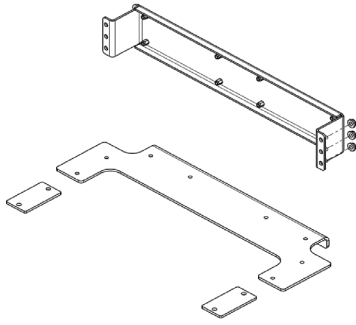

Required mounting bracket illustrated.
Available in 2', 3' or 4'. Electric kits come with
grease shield and clips while gas kit comes with
flue draft diverter.

XLR8 Upper Heated Platen	
Model #	XLR82401B-00
Phase	1
Volts	208 V 240 V
Amps	10 A 11.2 A
Watts	2.1 kW 2.7 kW
Breaker Size	15A
NEMA Plus (208/240)	L6-30P
Unit Width (one arm)	11 9/16"

Notes:

1. Each XLR8™ Arm comes with 6' power cord, separate receptacle needed for each unit.
2. For use on individual branch circuit only.

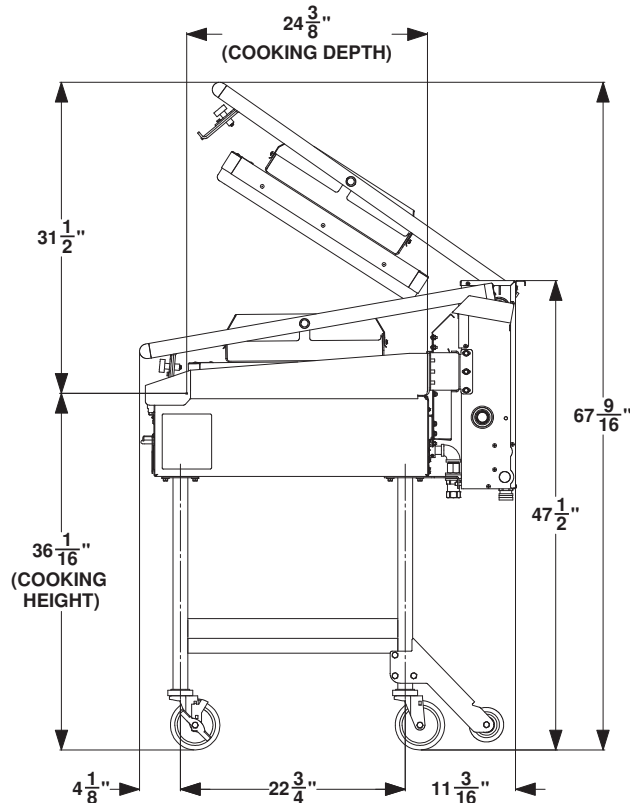
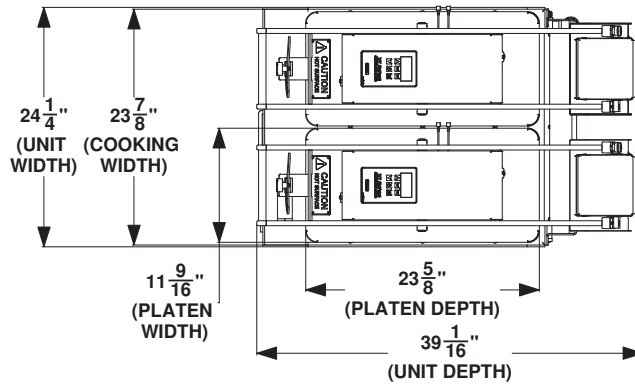
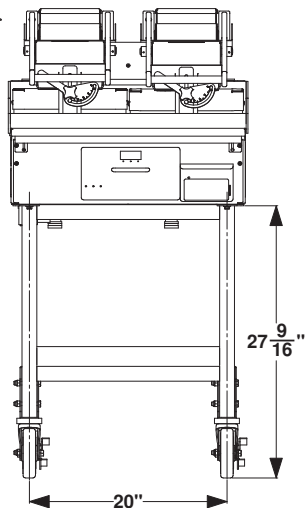
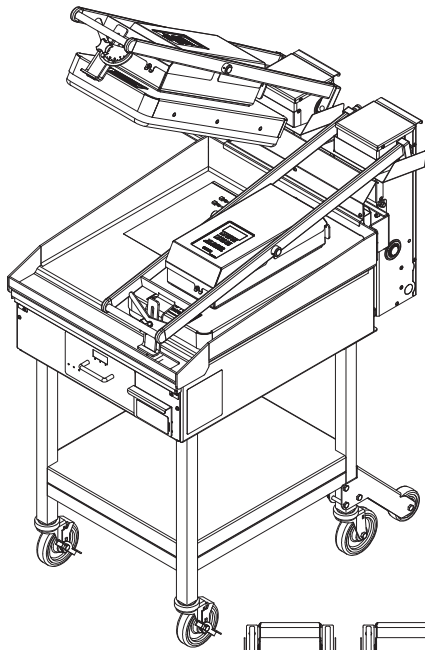

Drawing shown with (2) XLR8 Upper Heated Arms and Required Stand Stabilizer Brace Assembly.